

SOUTH



**N9/N7 Series
Total Station**

Operation Manual

Contents

FOREWORD	1
PRECAUTIONS	2
BATTERY NOTIFICATION	3
 SAFETY GUIDE	4
1. NOMENCLATURE AND FUNCTIONS	6
1.1 NOMENCLATURE	6
1.2 KEYPAD	8
2. SYNCHRONIZATION WITH PC	10
2.1 THE INSTALLATION OF MICROSOFT WINDOWS MOBILE DEVICE CENTER.....	10
2.2 CONNECTING TOTAL STATION WITH PC.....	11
3. KNOWING ABOUT YOUR N7/N9 SERIES	12
3.1 OPERATING SYSTEM	12
3.2 SETTING YOUR TOTAL STATION	12
3.2.1 <i>BACKLIGHT ADJUSTMENT</i>	13
3.2.2 <i>TOUCH-SCREEN ADJUSTMENT</i>	14
3.3 APPROACHES TO INPUT NUMBER AND CHARACTER	15
4. STAR KEY (★) MODE	20
5. PREPARATION FOR MEASUREMENT	23
5.1 UNPACKING AND STORAGE OF INSTRUMENT	23

5.2 INSTRUMENT SETUP	23
5.3 BATTERY INFORMATION	27
5.4 REFLECTOR PRISM	28
5.5 MOUNTING AND DISMOUNTING INSTRUMENT FROM TRIBRACH	29
5.6 EYEPIECE ADJUSTMENT AND COLLIMATING OBJECT	30
5.7 VERTICAL AND HORIZONTAL ANGLE TILT CORRECTION	30
6. BASIC SURVEY	32
6.1 ANGLE MEASUREMENT	34
6.1.1 HORIZONTAL ANGLE (RIGHT ANGLE) AND VERTICAL ANGLE MEASUREMENT.....	34
6.1.2 SWITCH HORIZONTAL ANGLE RIGHT/LEFT.....	35
6.1.3 HORIZONTAL ANGLE READING SETTING.....	36
6.1.4 VERTICAL ANGLE PERCENTAGE (%) MODE.....	39
6.1.5 ANGLE REPETITION MEASUREMENT	39
6.2 DISTANCE MEASUREMENT	40
6.2.1 SETTING ATMOSPHERE CORRECTION	44
6.2.2 ATMOSPHERIC REFRACTION AND EARTH CURVATURE CORRECTION.....	48
6.2.3 SETTING TARGET TYPE	49
6.2.4 SETTING THE PRISM CONSTANT	50
6.2.5 DISTANCE MEASUREMENT (CONTINUOUS MEASUREMENT).....	52
6.2.6 DISTANCE MEASUREMENT (SINGLE/N-TIME MEASUREMENT)	53
6.2.7 FINE/TRACKING MEASUREMENT MODE.....	55
6.3 COORDINATE MEASUREMENT	56
6.3.1 SETTING COORDINATE VALUES OF OCCUPIED POINT	56
6.3.2 SETTING THE BACKSIGHT POINT	58
6.3.3 SETTING THE INSTRUMENT HEIGHT/ PRISM HEIGHT.....	59

6.3.4 OPERATION OF COORDINATE MEASUREMENT	60
7. APPLICATION PROGRAMS	63
7.1 LAYOUT	63
7.2 REMOTE ELEVATION MEASUREMENT (REM)	64
7.2.1 INPUTTING PRISM HEIGHT (H)	65
7.2.2 WITHOUT INPUTTING PRISM HEIGHT	67
7.3 MISSING LINE MEASUREMENT (MLM)	69
7.4 LINE MEASUREMENT (LINE)	72
7.5 TRAVERSE MEASUREMENT (RESTORE NEZ)	76
7.6 OFFSET MEASUREMENT (OFFSET)	79
7.6.1 ANGLE OFFSET	80
7.6.2 DISTANCE OFFSET	82
7.6.3 COLUMN OFFSET	85
7.6.4 PLANE OFFSET	87
7.7 PARAMETERS SETTING	90
8. START STANDARD SURVEYING PROGRAM	93
9. PROJECT	98
9.1 CREATE NEW PROJECT	98
9.2 OPEN PROJECT	100
9.3 DELETE PROJECT	101
9.4 PROJECT OPTION	102
9.5 GRID FACTOR	104
10. DATA EXPORT/IMPORT	107

10.1 DATA EXPORT	107
10.2 DATA IMPORT	110
11. RECORD MEASUREMENT DATA	112
11.1 SETTING OCCUPIED POINT AND BACKSIGHT POINT	112
11.2 BACKSIGHT OBSERVATION (BS OBS)	125
11.3 FORESIGHT OBSERVATION (FS OBS)	127
11.4 SIDESHOT OBSERVATION (SS OBS)	130
11.4.1 OFFSET	132
11.4.2 PLANE OFFSET	134
11.4.3 PT. LINE MODE (FOR MEASUREMENT FROM POINT TO LINE)	139
11.4.4 CONTROL INPUT	142
11.5 CROSS SECTION MEASUREMENT	143
12. EDIT DATA	147
12.1 EDIT RAW DATA	148
12.2 EDIT COORDINATE DATA	150
12.2.1 EDIT COORD. DATA	151
12.2.2 ADD COORD. DATA	153
12.2.3 DELETE COORD. DATA	154
12.3 EDIT FIXED POINT DATA	155
12.4 CODE DATA	155
12.4.1 CREATE NEW LAYER	156
12.4.2 EDIT CODE LAYER/CODE	157
12.4.3 DELETE CODE	159
12.5 FILL/ CUT DATA	160

13. PROGRAM MENU	161
13.1 SET OUT	161
13.1.1 OCCUPIED POINT & BACKSIGHT POINT	161
13.1.2 POINT SET OUT	163
13.1.3 STRING SETOUT	169
13.1.4 REFERENCE LINE	170
WHAT REFERENCE LINE IS:	170
13.2 ROAD DESIGN AND LAYOUT	177
13.2.1 DEFINE HORIZONTAL ALIGNMENT	177
13.2.2 EDIT HORIZONTAL ALIGNMENT	186
13.2.3 DEFINE VERTICAL ALIGNMENT	186
13.2.4 EDIT VERTICAL ALIGNMENT	189
13.2.5 ALIGNMENT SETOUT	191
13.2.6 SLOPE SETOUT	195
13.2.7 CROSS SECTION SETOUT	199
13.3 COGO	202
13.3.1 INTERSECTION	202
13.3.2 4-INTERSECTION	205
13.3.3 INVERSE	207
13.3.4 AREA	208
13.3.5 MISSING LINE MEASUREMENT	212
.....	217
13.4 TRAVERSE ADJUSTMENT	218
13.5 BATTER BOARDS	224
13.5.1 METHOD 1: BATTER BOARD USING TWO SIDES	225

13.5.2 METHOD 2: BATTERBOARDS USING ONE SIDE	229
13.6 TAPE DIMENSIONS	231
14. SYSTEM SETTINGS	235
15. CHECK AND ADJUSTMENT	239
15.1 PLATE VIAL	239
15.2 CIRCULAR VIAL	240
15.3 INCLINATION OF RETICLE	240
15.4 PERPENDICULARITY BETWEEN LINE OF SIGHT AND HORIZONTAL AXIS	242
15.5 VERTICAL INDEX DIFFERENCE COMPENSATION	245
15.6 ADJUSTMENT OF VERTICAL INDEX DIFFERENCE (I ANGLE) AND SETTING VERTICAL INDEX 0	245
15.7 HORIZONTAL AXIS ERROR COMPENSATION ADJUSTMENT	248
15.8 OPTICAL PLUMMET	248
15.9 INSTRUMENT CONSTANT (K)	251
15.10 PARALLELISM BETWEEN LINE OF SIGHT AND EMITTING AXIS	253
15.11 TRIBRACH LEVELING SCREW	254
15.12 RELATED PARTS FOR REFLECTOR	254
16. TECHNICAL SPECIFICATION	256
17. ACCESSORIES	259
【APPENDIX-A】	260
1. EXPORT DATA FROM TOTAL STATION	260
1.1 RAW DATA FORMAT	260
1.2 COORDINATE DATA FORMAT	261

2. IMPORT DATA TO TOTAL STATION	261
2.1 COORDINATE DATA/FIXED POINT DATA FORMAT	262
2.2 CROSS SECTION DATA FORMAT	262
2.3 POINT P CODING FORMAT	263
2.4 HORIZONTAL LINE	264
2.5 VERTICAL CURVE.....	265
【APPENDIX-B】 CALCULATE ROAD ALIGNMENT.....	266
1. ROAD ALIGNMENT ELEMENTS	266
2. CALCULATION ROAD ALIGNMENT ELEMENTS	268

FOREWORD

Thank you for purchasing Electronic Total Station N7/N9 Series.

The WIN-CE interface of N7/N9 is very similar with a Windows-based PC, You can connect them easily and realize real-time data exchanging and processing on both ends.

This manual is applicable to: N7/N9 Series Total Station.

Please read the manual completely before operating the instrument.

PRECAUTIONS

1. Do not collimate the objective lens direct to sunlight without a filter.
2. Do not store the instrument in high and low temperature to avoid the sudden or great change of temperature.
3. When the instrument is not in use, place it in the case and avoid shock, dust and humidity.
4. If the temperature varies greatly between work site and the instrument depository, do not set to work as soon as arrived; leave the instrument in the case for a while till it adapted environment temperature.
5. When storing the instrument long time without use, disconnect the battery from the device. The battery should be charged once a month.
6. Please give special attention to the packing Shock absorption is very important in long distance transportation.
7. For less vibration and better accuracy, the instrument should be set up on a wooden tripod rather than aluminum tripod.
8. Clean exposed optical parts with degreased cotton or lens tissue only.
9. If the instrument gets wet in the rain, do not try to power it on at once, clean the surface with a soft cloth and then keep the instrument in a well-ventilated place.
10. Before set up the job, check initial settings of the instrument as well as the parameters.
11. Unless the user is a maintenance specialist, do not attempt to disassemble the instrument by oneself.
12. When the laser is switched on, do not look into the objective Len with naked eye.

BATTERY NOTIFICATION

1. Battery should be recharged only with the charger LC-01 which comes with the total station.

2. Battery Recharging Cautions:

The charger has built-in circuitry for protection from overcharging. However, do not leave the charger plugged into the power outlet after recharging is completed. Be sure to recharge the battery at a temperature of $0^{\circ}\sim\pm 45^{\circ}\text{C}$, recharging may be abnormal beyond the specified temperature range. Prohibit the use of any charger or battery that has been damaged.

3. Battery Storage Cautions:

Rechargeable battery can be repeatedly recharged 300 to 500 times. Long time totally discharge of a battery may shorten its life. The battery should be recharged at least one time a month, which will help increase its full charge capacity. Do not keep the battery at high heat and damp places. Do not short-circuit the battery. Dispose of batteries properly. Do not throw them into fire or expose to high temperature.

SAFETY GUIDE

For laser EDM (visible laser)

Warning:

The total station is equipped with an EDM of a laser grade---3R/IIIa. It is verified by the following labels.

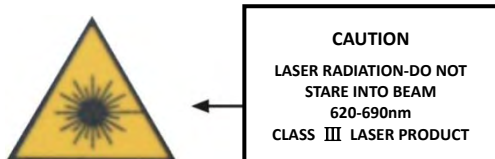

Over the vertical tangent screw sticks an indication label “CLASS III LASER PRODUCT”.

A similar label is pasted on the opposite side.

This product is classified as Class 3R laser product, which accords to the following standards.

IEC60825-1:2001 “SAFETY OF LASER PRODUCTS”.

Class 3R/III a laser product: It is harmful to observe laser beam continuously. User should avoid sighting the laser at the eyes. It can reach 5 times the emitting limit of Class2/II with a wavelength of 400mm-700mm.

Warning:

Continuously looking straight at the laser beam is harmful.

Prevention:

Do not stare at the laser beam, or point the laser beam to others’ eyes. Reflected laser beam is a valid measurement to the instrument.

Warning:

When the laser beam emits on prism, mirror, metal surface, window, etc., it is dangerous to look straight at the reflex.

Prevention:

Do not stare at the object which reflects the laser beam. When the laser is switched on (under EDM mode), do not look at it on the optical path or near the prism. It is only allowed to observe the prism with the telescope of total station.

Warning: Improper operation on laser instrument of Class 3R will bring dangers.

1. NOMENCLATURE AND FUNCTIONS

1.1 NOMENCLATURE







1.2 KEYPAD



Functions of the Keys

Key	Nomenclature	Function
	Power Key	To switch power ON/OFF.
0 ~ 9	Numeric Key	To input desired numbers.
A ~ /	Alpha Key	To input alphabets.
	Inputting Panel Key	To display inputting panel.
B.S	Backspace	To delete one character leftward when inputting numbers or alphabets.
	Cursor Key	To move the cursor up/down/left/right.
α	Alpha Shifting Key	To shift to alphabet inputting mode.

★	Star Key	To launch several common functions
ESC	ESC Key	Quit to previous screen or previous mode.
ENT	Enter Key	To finish and accept the data input.
SP	Space Key	To Input space
ALT	Alt Key	Same function on PC
TAB	Tab key	To move cursor rightward or to next character field

2. SYNCHRONIZATION WITH PC

2.1 The Installation of Microsoft Windows Mobile Device Center.

There is a CD attached with the instrument. Put it into your CD-ROM and install Windows Mobile, then you can establish Windows Mobile connection between N7/N9 and Computer.

Before Installing Windows Mobile Device Center

Before installing, read the following words carefully:

- During the installation processing, reboot your computer is required. Therefore, please save your jobs and quit all the applications before installation.
- To install Windows Mobile Device Center, you are supposed to have an USB cable (available in the product package) connect the TS with PC.

Installing Windows Mobile Device Center

- put the CD in the drive.

Windows Mobile Device Center Installation Guide will be run automatically.

- Click "Next" to install Windows Mobile Device Center.



2.2 CONNECTING TOTAL STATION WITH PC

- Connect the N7N9 and computer with the USB cable.
- Power the total station on. The software will detect the Total station and setup the communication. When connection established successfully, the following message will display.

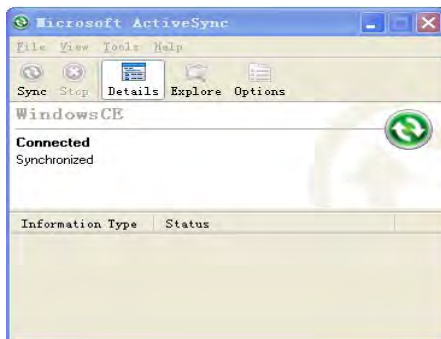

Using "Browse" Function

After the synchronization, you can click "Browse" button to view the files stored in the total station. Copy, paste and deletion are synchronized on both ends. See the picture below.

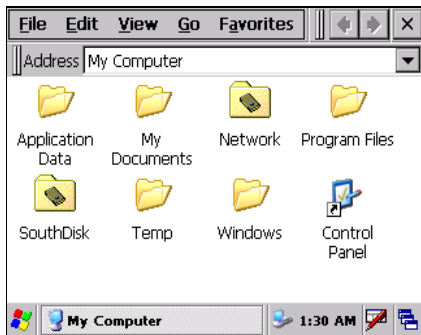

3. KNOWING ABOUT YOUR N7/N9

Press POWER to turn on the instrument. See the initial interface as below.

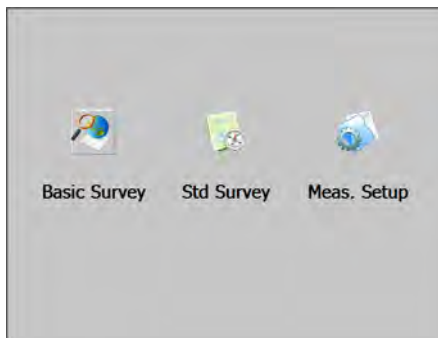

3.1 OPERATING SYSTEM

N7/N9 is based on Windows CE operating system; WINCE is quite similar to Windows system. The functions and interfaces are easy to use for the surveyor.

Note: we also offer powerful mapping software in N7/N9. WinMG (Mapping Genius) and WinEG (Engineering Genius). They can help you to finish most of the office work soon after field measuring.





3.2 SETTING YOUR TOTAL STATION

You can adjust the default settings of N7/N9 according to the following steps.

3.2.1 Backlight adjustment

The system will automatically shut the backlight when battery is running low.

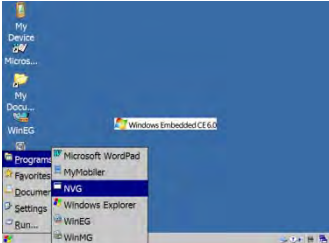

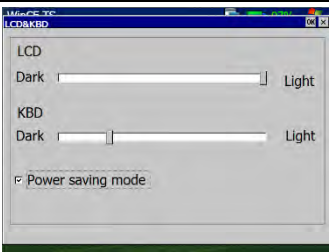



You can also adjust the brightness of backlight as following steps.

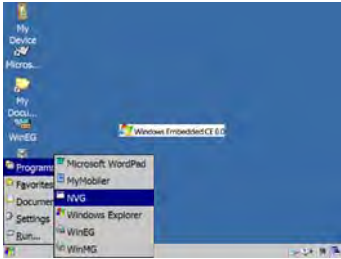

OPERATIONAL STEPS	KEY	DISPLAY
<p>① Click the NVG program from START menu</p>	 	
<p>② Press turn page button to Page 3. You can see the BKLight icon.</p>	<p>Backlight</p>	
<p>③ Taps on bar location to adjust brightness and keyboard backlight.</p>	<p>[OK]</p>	

There is option to open Power Saving mode or not, if you click it, the screen will light on one side which you operate, and the other side will be off to save battery energy.

3.2.2 Touch-screen Adjustment

If your device is not responding accurately to screen taps, Adjust the touch screen by the following steps.



OPERATION STEPS	KEY	DISPLAY
<p>① Click the NVG program from START menu</p>	 	
<p>② Press turn page button to Page 1. You can see the Calibration icon. .</p>	 Calibration	
<p>③ Click “Calibration”, and then “Recalibrate”.</p>	Calibration + Recalibrate	

<p>④ According to the prompt, use the stylus to click the cross center. Repeat as the cross moves around the screen. Totally adjust 5 points as guide.</p>		
<p>⑤ Press [ENT] to save new setting, Press [Esc] to return to control panel.</p>	<p>[ENT] + [Esc]</p>	

3.3 APPROACHES TO INPUT NUMBER AND CHARACTER

For Total Station N7/N9, two kinds of inputting approaches are available. One is using the keyboard, like the keyboard of a mobile phone, with 3 characters on one key. Press it once to display the first characters. Press it twice to display the second one. And press it three times to display the third character. The other way is using soft keyboard. Press icon [] to enter inputting interface. As an example, here we create a folder named "Job-1".

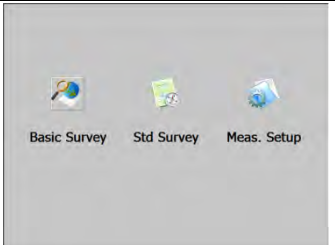
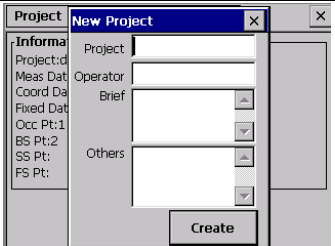
[Example 1: Inputting by soft keyboard]

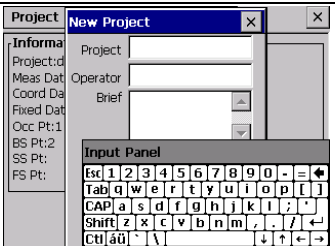
OPERATION STEPS	KEY	DISPLAY
Click the “StdSurvey” to open Standard Survey Program	Std Survey	
Click “project” and choose “New project” on the pull-down menu.	Project	
Press  button to open the soft keyboard		

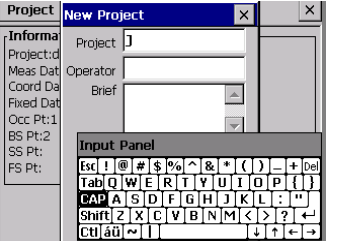
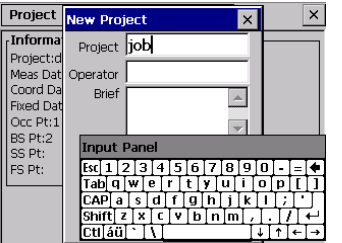
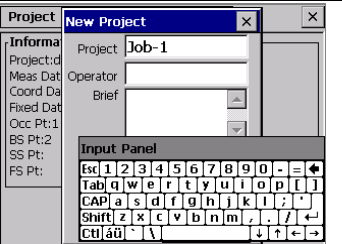
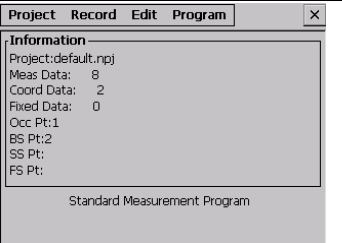

<p>One can switch between capital letter and lower-case though “shift” on the softkeyboard.</p> <p>Input “J”.</p>	<p>[shift] + [J]</p>	
<p>The system autoreturns to small letter inputting mode.</p> <p>Use the stylus to click characters key [o] and [b] to input “o” and “b”.</p>	<p>[o] [b]</p>	
<p>Click [-] to input “-”</p> <p>Click number [1] to input “1”.</p>	<p>[-] [1]</p>	
<p>After inputting, press the “Shift” to close the soft keyboard.</p> <p>Press [ENT] to create the current working project.</p>	<p>Shift [ENT]</p>	
<p>Press [Esc] key to close soft keyboard.</p>		

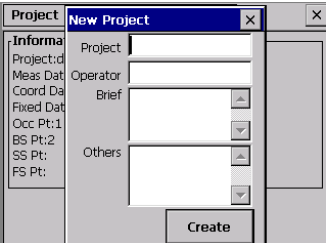
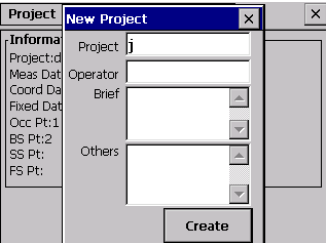
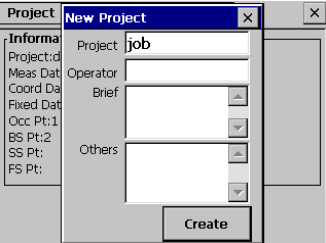
[Example 2: Input by physical keyboard]

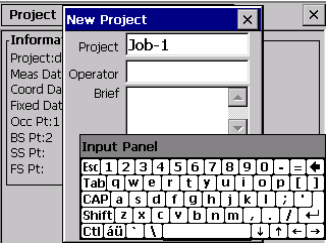
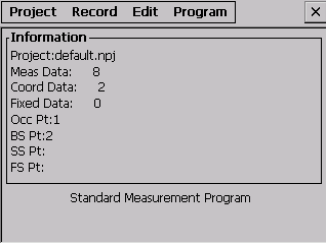
OPERATIONAL STEPS	KEY	DISPLAY
<p>① Click “project” and choose “New project” on the pull-down menu.</p>		
<p>② Switch to character input mode by press [@]. Then press [4] one time to input a capital letter ‘J’.</p>	<p>[@] [4]</p>	
<p>③ Press [5] twice quickly to input letter “o”, [7] twice quickly to input “b”.</p>	<p>[5] [5] [7] [7]</p>	

<p>④ Press [α] key to switch back to number input mode and press [-] to input-and [1] to input the number “1”.</p>	<p>[α] [-] [1]</p>	
<p>⑤ After inputting, press [ENT] key.</p>	<p>[ENT]</p>	

※1) press  key one time to open the soft keyboard. Press again to close it.

Or using stylus  to select “Keyboard” on pop-up menu to activate soft keyboard. When soft keyboard is activated, press  and select “Hide Input Panel” to close soft keyboard.

※2) Under the status of letter inputting mode, each key has defined 3 letters. Every time pressing will display one letter. Thus pressing once can display the first letter, the same key twice for the second, and three times to display the third letter.

4. STAR KEY (★) MODE

Press the (★) to view the common settings.

TILT: Electric Circular Vial Graphic Display.

ATMOS: Set the Temperature, Pressure, Atmospheric Correction Value (PPM) and Prism constant value (PSM).

TARGET: to set Target Type, Crosshair light, to check Signal (strength) level.

1. Electric circular bubble graphic display

Electric circular bubble can be displayed by graphic. This function will help you leveling the instrument when the circular vial is hid behind the Main body of the instrument.

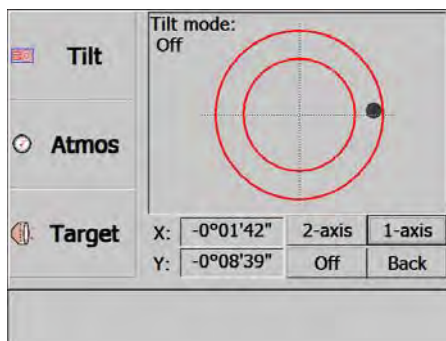

Rotate the leveling screws while observing electric circular bubble. After the bubble centered at the cross point, press [Back] to return the previous interface.

2. Set the Temperature ,Pressure, Atmospheric Correction Value (PPM) and Prism constant value (PSM)

Click [Atmos] to view the Temperature, Pressure, PPM and PSM. To modify parameters, point the cursor to the textbox by stylus, and input the new value.

Please Refer to “14. SYSTEM SETTINGS” for the detail.

Tilt	Input	Automatic
Atmos	Temp 26.9 °C	
Target	Pres 1015.9 hPa	
	PPM 5 ppm	
	PSM 0	
	Version:2013.02.	Save

3. Set the target type, illumination of crosshair and check the signal intensity.

Click [Target], target type, illumination of cross hair, etc. can be set.

Setting of target type:

There are two measuring modes for N7/N9 series: visible laser EDM and invisible laser EDM. The reflector can be set as Prism, Non-prism and Reflecting Sheet.

Refer to “technical parameters” for the parameter of different reflectors.

Setting of illumination of cross hair:

- Move the stylus to adjust the brightness of crosshair.

L: Indicate that the crosshair is dim.

H: Indicate that the crosshair is bright

Move the stylus from left to right to change the brightness of the crosshair from dim to bright.

Setting of signal mode:

The reflector return signal intensity was displayed in this mode. It will buzzer when return signal from the prism was received. This function is more convenient for collimation when the target is difficult to find.

The received return signal level is displayed with bar graph as follows.

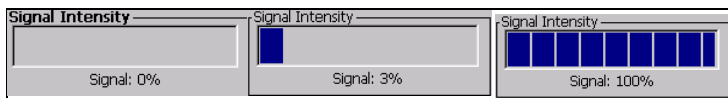
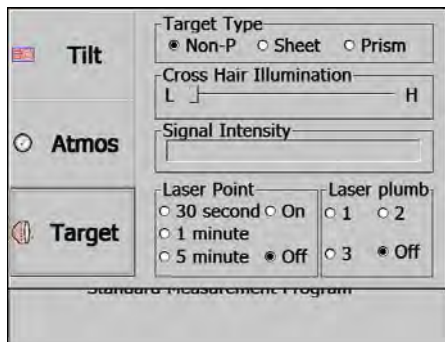

No light acceptance Minimum quantity level Maximum quantity level

- Setting of Laser Pointer and Laser Plumb:** change the on/off and working time of Laser pointer; set the on/off and intensity of the laser plumb

5. PREPARATION FOR MEASUREMENT

5.1 UNPACKING AND STORAGE OF INSTRUMENT

- Unpacking of instrument

Keep the case right side up with care, and open the instrument container and take out the instrument.

- Storage of instrument

Cover the objective lens with the cap and place the instrument into the case. Make sure the vertical clamp screw and circular vial stay upwards (Objective lens towards tribrach), and slightly tighten the vertical clamp screw and lock the case.

5.2 INSTRUMENT SETUP

Put the instrument on the tripod. Level and center the instrument precisely.

Operation Reference:

1. Leveling and Centering the Instrument by plumb bob

1) Set up the tripod

① Adjust the tripod legs to suitable length, make the tripod head parallel to the ground and tighten the screws.

② Make the centre of the tripod and the occupied point approximately on the same plumb line.

③ Set the tripod and make sure it is well stationed on the ground.

2) Put the instrument on the tripod

Put the instrument carefully on the tripod head and slide the instrument by

SOUTH

loosening the tripod head screw. If the plumb bob is positioned right over the center of the point, slightly tighten the tripod head screw.

3) Roughly leveling the instrument by using the circular vial bubble.

① Turn the leveling screw A and B to move the bubble in the circular vial, in which case the bubble is located on a line perpendicular to a line running through the centers of the two leveling screw being adjusted .

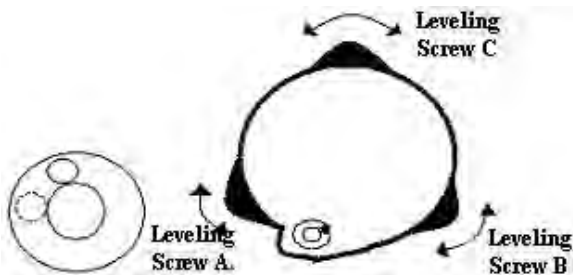

Turn the leveling screw C to move the bubble to the center of the circular vial.



4) Precisely leveling by using the plate vial

① Rotate the instrument horizontally by loosening the Horizontal Clamp Screw and place the plate vial parallel to the line connecting leveling screw A and B, and then bring the bubble to the center of the plate vial by turning the leveling screws A and B.

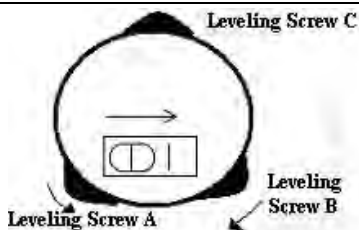

- ② Rotate the instrument 90° (100g) around its vertical axis and turn the remaining leveling screw or leveling C to center the bubble once more.

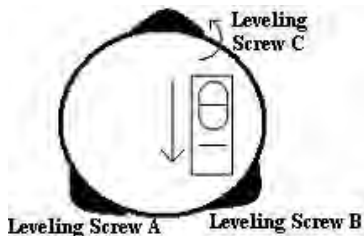

- ③ Repeat the steps ①② for each 90° (100g) rotation of the instrument and check whether the bubble is correctly centered in all directions.

2. Centering by using the optical plummet

1) Set tripod

Set up tripod to suitable height, ensure equal length of three legs, spread and make tripod head parallel to the ground, and place it right above the measurement station point. Prop up tripod on the ground and fix one leg.

2) Install instrument and collimate the point

Set instrument carefully on tripod, tighten the central connecting screw and adjust

optical plummet to make the reticle distinctly. Hold the other two unfixed legs with both hands and adjust position of these two legs through observation of optical plummet. As it approximately aims at the station point, make all three legs fixed on the ground. Adjust three leg screws of the instrument to make optical plummet collimate precisely to the station point.

3) Use circular vial to roughly level the instrument.

Adjust length of three legs of tripod; make the circular vial bubble of the instrument in the middle.

4) Use plate vial to level the instrument accurately.

① Rotate the instrument horizontally by loosening the

Horizontal Clamp Screw and place the plate vial parallel to the line connecting leveling screw A and B, and then bring the bubble to the center of the plate vial by turning the leveling screws A and B.

② Rotate the instrument 90° , make it perpendicular to the connecting line of level screws A and B. Turn level screw C to make the bubble of the plate vial in the middle.

5) Precisely centering and leveling

Through observation of optical plummet, slightly loosen the central connecting screw and move the instrument evenly (Don't rotate the instrument), making the instrument precisely collimating to the station point. Then tighten the central connecting screw and level the instrument precisely again.

Repeat this operation till the instrument collimate precisely to the measurement station point.

5.3 BATTERY INFORMATION

Notice:

① The battery operating time will vary depending on the environmental conditions such as ambient temperature, charging time, the number of times of charging and discharging etc. It is recommended for safety to charge the battery beforehand or to prepare spare full charged

batteries.

② The battery icon shows the power level regarding the current measurement mode. The distance measurement mode consumes more power than angle measurement mode, so the power enough for the latter is not sure applicable for the previous one. Pay attention to this when switching angle measurement mode to distance measurement mode, because insufficient battery power might lead to interrupted operation.

● Battery status should be well checked before outdoor operation.

③ When the measurement mode is changed. The battery power would not immediately show the decrease or increase. The battery power indicating system shows the general status but not the instantaneous change of battery power.

• Battery Recharging Cautions:

☆ Battery should be recharged only with the chargerSD841201 going with the instrument.

Remove the on-board battery from instrument and connect it to battery charger. When the indicator lamp on the battery charger is orange, the recharging process has

begun. When charging is complete (indicator lamp turns green), disconnect the charger from its power source.

•Battery Removal Cautions:

Before removing the battery from the instrument, make sure that the power is turned off. Otherwise, the instrument may be damaged.

•Battery Recharging Cautions:

The charger has built-in circuitry for protection from overcharging. However, do not leave the charger plugged into the power outlet after recharging is completed.

Be sure to recharge the battery at a temperature of $0^{\circ}\sim\pm 45^{\circ}\text{C}$, recharging may be abnormal beyond the specified temperature range .

When the indicator lamp does not light after connecting the battery and charger, either the battery or the charger may be damaged. Please connect professionals for repairing.

•Battery Charging Cautions:

Rechargeable battery can be repeatedly recharged 300 to 500 times. Complete discharge of the battery may shorten its service life. In order to get the maximum service life, Make sure you recharge it at least once a month.

5.4 REFLECTOR PRISM

When measuring the distance, a reflector prism needs to be placed at the target point. Reflector systems come with single prism and triple prisms, which can be mounted with tribrach onto a tripod or mounted onto a prism pole. Reflector systems can be self-configured by users according to job.



5.5 MOUNTING AND DISMOUNTING INSTRUMENT FROM TRIBRACH

·Dismounting

If necessary, the instrument (including reflector prisms with the same tribrach) can be dismounted from tribrach. Loosen

the tribrach locking screw in the locking knob with a screwdriver. Turn the locking knob about 180° counter-clockwise to disengage anchor jaws, and take off the instrument from tribrach.

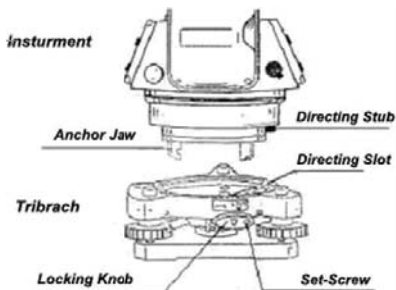

·Mounting

Insert three anchor jaws into holes in tribrach and line up the directing stub with the directing slot. Turn the locking knob about 180° clockwise and tighten the locking screw with a screwdriver.

5.6 EYEPIECE ADJUSTMENT AND COLLIMATING OBJECT

Method of Collimating Object (for reference)

① Sight the Telescope to bright place and rotate the eyepiece tube to make the reticle clear.

② Collimate the target point with top of the triangle mark in the coarse collimator. (Keep a certain distance between eye and the coarse collimator).

Make the target image clear with the telescope focusing screw.

☆ if there is parallax when your eye moves up, down or left, right, it means the diopter of eyepiece lens or focus is not well adjusted and accuracy will be influenced, so you should adjust the eyepiece tube carefully to eliminate the parallax.

5.7 VERTICAL AND HORIZONTAL ANGLE TILT CORRECTION

When the tilt sensors are activated, there will be an automatic compensation value added into the vertical and horizontal angles.

Tilt sensor must be turned on; it can help improve the precision. When a dialog of compensation displays, it indicates that the instrument is out of automatic compensation range ($\pm 3.5'$), and must be leveled manually.

N7/N9 Series compensates the inclination in both X and Y directions.

Example:

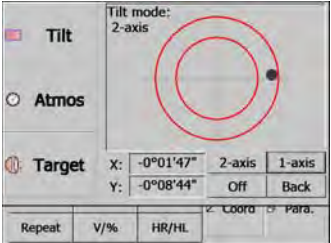
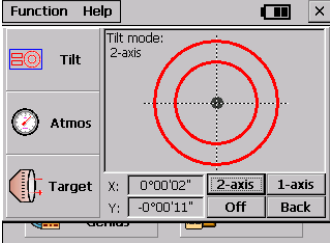
OPERATION STEPS	KEY	DISPLAY
<p>If the instrument hasn't been leveling, a compensation dialog box will pop up automatically. As shown in the right graph.</p>	<p>STAR key</p>	
<p>Turn the leveling screw to make the black dot move into the small circle. When the small black dot is in the small circle, it means the instrument is within the auto tilt compensation scale $\pm 3.5'$. If it is outside the small circle, the instrument needs to be leveled manually.</p>		
<p>To set it to single axis compensation, click [1-axis]; To close compensation, click [OFF]; To return to previous mode, click [Back].</p>		

- When the instrument is set on an unstable stage especially in a windy day. You may turn off the auto tilt correction function; otherwise it may leads to a wrong value.
- If the tilt sensor turn on already (Single Axis or Dual Axis), you can level the instrument according to the electronic bubble show above.

6. BASIC SURVEY

On desktop of N7/N9 click  to open the program of basic survey, as shown in the following graph:

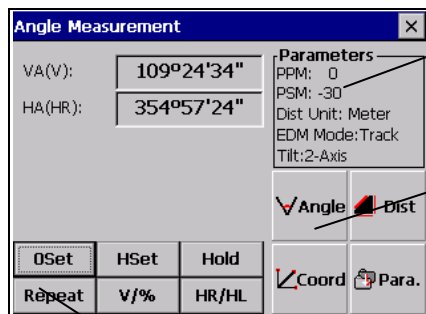
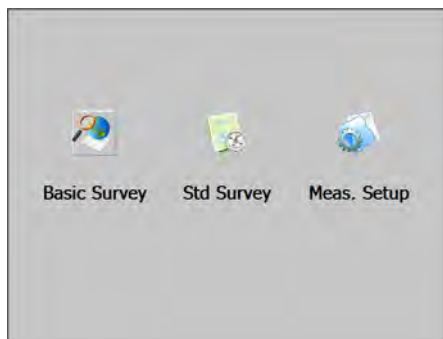

Current parameters





Mode key

Function key

Description of each function key:

Function keys display at the bottom of the screen, which change with the measure mode.



The following graph lists each function key in every measure mode.

Mode	Display	Soft key	Function
	0 Set	1	0 Set horizontal angle.
	HSet	2	Preset a horizontal angle.
	Hold	3	Hold horizontal angle.
	Repeat	4	Repeat horizontal angle measurement.
	V%	5	Switch vertical angle and percentage.
	HR/HL	6	Switch horizontal angle right/left
 	Mode	1	EDM mode: Fine[s]/ Fine[N]/ Fine [r]/Track
	m/ft	2	Distance unit: meter/Feet/U.S.
	layout	3	Layout measure mode
	REM	4	Start Remote Elevation Measurement.
	MLM	5	Start Missing Line Measurement.
	Line	6	Start Line Height Measurement.
	Mode	1	EDM mode: Fine[s]/ Fine[N]/ Fine [r]/Track
	Occ	2	Preset coordinates of occupied point.
	BS	3	Preset coordinates of backsight point.
	Setup	4	Preset instrument height and target height.
	Store	5	Start store function.
	Offset	6	Start Offset measurement. (Angle Offset (1) /Distance Offset (2)/Column Offset (3)/Plane Offset (4)).

6.1 ANGLE MEASUREMENT

6.1.1 Horizontal Angle (Right Angle) and Vertical Angle Measurement

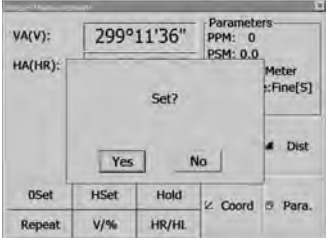
Make sure the mode is Angle measurement.

OPERATION STEPS	KEY	DISPLAY
<p>① Sight the first target A.</p>	<p>Sight target A</p>	
<p>② Set the horizontal angle of target A as 0°00'00\".</p> <p>Click [0 SET], press [YES] to confirm.</p>	<p>[0 Set] [YES]</p>	
<p>③ Sight second target (B).</p> <p>The screen displays the horizontal and vertical angle of target B.</p>	<p>Sight B</p>	

How to collimate the targets (For reference)

- ① Point the telescope toward the light, rotate the eyepiece ring, focalize the telescope so that the crosshair is clearly observed (turn the eyepiece ring to you first and then to focus) .
- ② Aim the target at the peak of triangle mark of the collimator. Keep a certain space between the collimator and yourself for collimation.
- ③ Focus the target with the focusing knob until the target is clearly seen and its center is right on the crosshair.

If parallax exists between the crosshair and the target when viewing vertically or horizontally through the telescope, focusing is incorrect or diopter adjustment is poor. This adversely affects precision in measurement or survey. So please eliminate the parallax by focusing and using diopter adjustment carefully.

6.1.2 Switch Horizontal Angle Right/Left

Make sure the mode is Angle measurement.

OPERATION STEPS	KEY	DISPLAY
① Make sure the mode is Angle measurement.		

<p>② Click [HR/HL] key, horizontal right angle measuring mode is shifted to left angle mode.※1)</p>	<p>[HR/HL]</p>	
<p>※1)Every time click [HR/HL] key, HR/HL is shifted in order.</p>		

6.1.3 Horizontal Angle Reading Setting

Setting by holding the angle

Make sure the mode is Angle measurement.

OPERATION STEPS	KEY	DISPLAY
<p>① Use horizontal clamp screw and horizontal tangent screw to set the required horizontal angle.</p>		
<p>② Click [Hold], hold the required horizontal angle.</p>	<p>[Hold]</p>	

<p>③ Collimate the target.※1)</p>		
<p>④ Click [Unlock] to release the horizontal angle. The display turns back to normal angle measurement mode, setting the current horizontal angle as the value held just now.</p>	<p>[Unlock]</p>	
<p>※1) To return to the previous mode, Click [Cancel].</p>		

2) Setting a Horizontal Angle from the keys

Make sure the mode is Angle measurement.

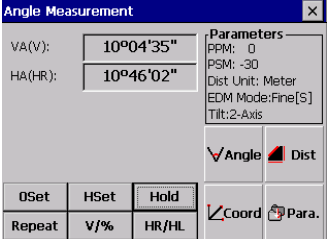
OPERATION STEPS	KEY	DISPLAY
<p>① Collimate the target.</p>		

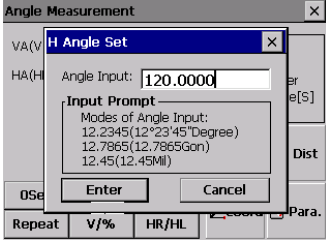
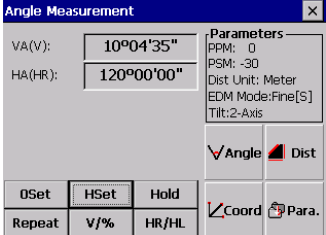
<p>② Click [HSet], a dialog box pops up.</p> <p>③ Input the required horizontal angle※1)、※2)</p> <p>For Example: 120°00'00"</p>	<p>[HSet] Input horizontal angle</p>	
<p>④ After inputting, press [ENT]※3)</p> <p>When completed, normal measuring from the required Horizontal angle is possible.</p>	<p>[ENT]</p>	
<p>※1) You can press [□] to open inputting panel, click the numbers to input, see “3.3 APPROACHES TO INPUTTING NUMBERS AND LETTERS”.</p> <p>※2) To revise wrong value, use stylus or press [▶]/[◀] moving the cursor to right of the number need to delete. Click [←] on the panel or press [B.S.] to delete wrong value and input correct one.</p> <p>※3) With wrong input value (for example 70'), Setting failed, press [ENT], the system doesn't respond, input again from step ③.</p>		

6.1.4 Vertical Angle Percentage (%) Mode

Make sure the mode is Angle measurement.

Example:

OPERATION STEPS	KEY	DISPLAY
<p>① Make sure the mode is Angle measurement.</p>		
<p>② Click [V/%].</p>	<p>[V%]</p>	
<p>※1) Every time Click [V/%], the display mode switches accordingly.</p>		

6.1.5 Angle Repetition Measurement

This program is used to angle repetition measurement, displaying the sum and average value of all observed angles. It records the observation times at the same time.

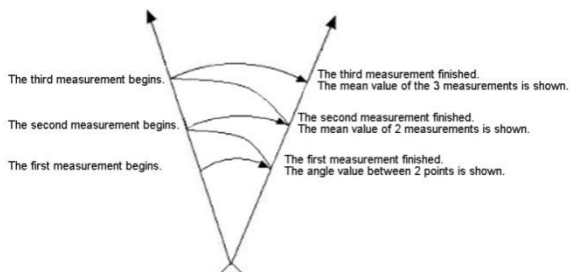

Example:

OPERATION STEPS	KEY	DISPLAY
<p>① Click [Repeat] to enter into Angle Repeat function.</p>	<p>[Repeat]</p>	
<p>② Sight the first target A.</p>	<p>Sight target A</p>	

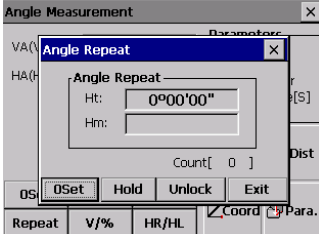
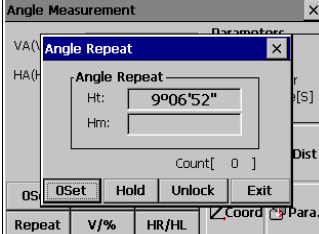
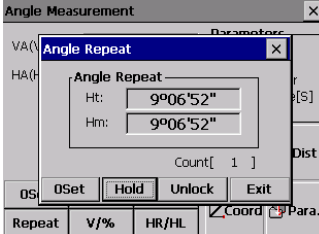
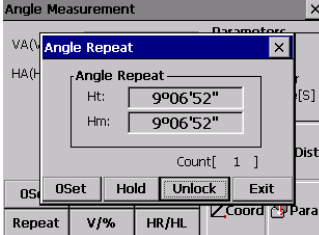
<p>③ Click [0 Set], 0 Set the horizontal angle.</p>	<p>[0 Set]</p>	
<p>④ Use horizontal clamp screw and horizontal tangent to sight the second target B.</p>	<p>Sight B</p>	
<p>⑤ Click [Hold].</p>	<p>[Hold]</p>	
<p>⑥ Use horizontal clamp screw and horizontal tangent to sight first target A again. ⑦ Click [Unlock].</p>	<p>Sight A again + [Unlock]</p>	

SOUTH

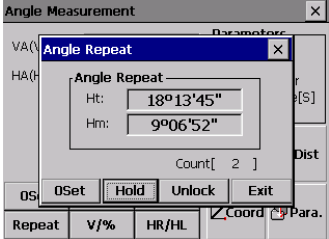
<p>⑧ Use horizontal clamp screw and horizontal tangent to sight the second target B again.</p> <p>⑨ Click [Hold].</p> <p>The total of angle (Ht) and the mean value of angle (Hm) are shown.</p>	<p>Sight B again</p> <p>[Hold]</p>	
<p>⑩ Repeat ⑧~⑨ to reach the desired number of repetition.</p>		
<p>Click [Exit] to quit angle repeat measurement.</p>		

6.2 DISTANCE MEASUREMENT

In basic surveying screen, click [Dist] to enter into distance measurement.

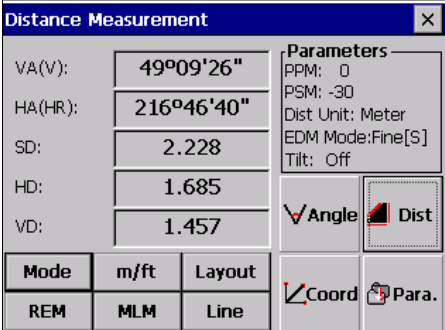

Distance Measurement			Parameters						
VA(V):	49°09'26"	PPM: 0 PSM: -30 Dist Unit: Meter EDM Mode: Fine[S] Tilt: Off <input checked="" type="checkbox"/> Angle <input type="checkbox"/> Dist							
HA(HR):	216°46'40"								
SD:	2.228								
HD:	1.685								
VD:	1.457								
<table border="1" style="width: 100%; border-collapse: collapse;"> <thead> <tr> <th style="width: 33%;">Mode</th> <th style="width: 33%;">m/ft</th> <th style="width: 33%;">Layout</th> </tr> </thead> <tbody> <tr> <td>REM</td> <td>MLM</td> <td>Line</td> </tr> </tbody> </table>		Mode	m/ft	Layout	REM	MLM	Line	<input checked="" type="checkbox"/> Coord <input type="checkbox"/> Para.	
Mode	m/ft	Layout							
REM	MLM	Line							

NOTE:

Do not aim at strongly reflecting targets (such as traffic lights). The measured distances may be wrong or inaccurate.

When the [DIST] is triggered, the EDM measures the object which is in the beam path at that moment.

If e.g. people, cars, animals, swaying branches, etc. cross the laser beam while a measurement is being taken, a fraction of the laser beam is reflected and may lead to incorrect distance values.

Avoid interrupting the measuring beam while taking reflectorless measurements or measurements using reflective foils.



Reflectorless EDM

- Ensure that the laser beams cannot be reflected by any object nearby with high reflectivity.

- When a distance measurement is triggered, the EDM measures to the object which is in the beam path at that moment. In case of temporary obstruction (e.g. a passing vehicle, heavy rain, snow, frog, etc.), the EDM may measure to the obstruction.

- When measuring longer distance, any divergence of the red laser beam from the line of sight might lead to less accurate measurements. This is because the laser beam might not be reflected from the point at which the crosshairs are pointing. Therefore, it is recommended to verify that the R-laser is well collimated with the telescope line of sight.

- Do not collimate the same target with the 2 total stations simultaneously.



Accurate measurements to prisms should be made with the standard program (infrared mode).



Red Laser Distance Measurement Cooperated with Reflective Foils.

The visible red laser beam can also be used to measure to reflective foils. To guarantee the accuracy the red laser beam must be perpendicular to the reflector foil and it must be well adjusted

Make sure the additive constant belongs to the selected target (reflector).

6.2.1 Setting Atmosphere Correction

● Distance measurement is influenced directly by the atmospheric conditions of the air in which distance measurement are taken.

In order to take into consideration these influences distance measurements are corrected by using atmospheric correction parameters.

Temperature: Air temperature at instrument location.

Pressure: Air pressure at instrument location.

Atmos PPM: Calculated and indicated atmospheric PPM.

6.2.1.1 Calculation of Atmospheric Correction

● The value of Atmospheric Correction can be influenced by air pressure, air temperature and the height. The calculating formula is as follows: (calculating unit: meter)

$$\text{PPM} = 273.8 - \frac{0.2900 \times \text{air pressure (hPa)}}{1 + 0.00366 \times \text{air temperature (}^{\circ}\text{C)}}$$

If the pressure unit adopted is mmHg: make conversion with:

1hPa = 0.75mmHg.

● The standard atmospheric condition of N7/N9 Series

(e.g. the atmospheric condition under which the atmospheric correction value of the instrument is zero) :

Pressure: 1013 hPa

Temperature: 20°C

If regardless of atmospheric correction, please set PPM value as 0.

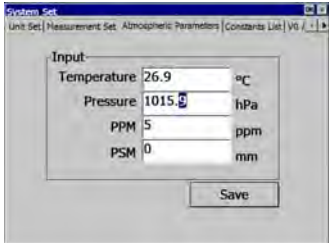
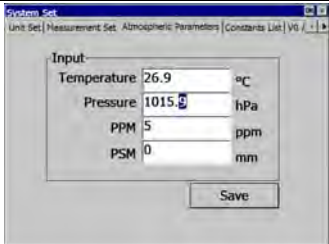
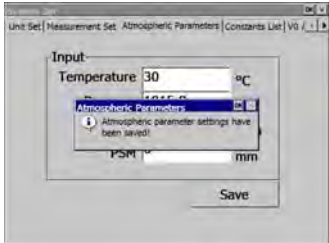
OPERATION STEPS	OPERATION	DISPLAY
<p>① In the menu of total station,click “Meas.Setup” and then click “Atmospheric Parameters”.</p>	<p>[Meas.Setup] [Atmospheric parameters]</p>	
<p>② Current Atmospheric Parameters display on the screen. Use stylus and input the new data. For instance, set the temperature as 26°C</p>	<p>Input Temperature</p>	
<p>③ According to the same steps, input the value of Air pressure. Click the “Save” after finishing setting.</p>	<p>Input Pressure + [Save]</p>	

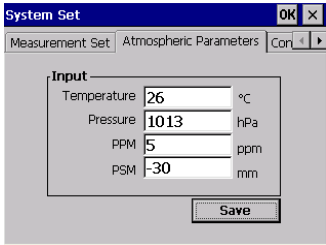
<p>④ Press [OK] to save these parameters. System will get PPM value from the value of temperature and air pressure, the screen displays as the right graph.</p>	<p>[OK]</p>	
---	-------------	---

※1) The inputting range: Temperature: -40~+60°C (step length 0.1°C) or -22~+140°F (step length 1°F)
 Air pressure: 420 ~ 800 mm Hg (step length 1 mm Hg) or 560 ~ 1066 hPa (step length 0.1 hpa)
 16.5 ~ 31.5 inchHg (step length 0.1 inchHg)
 Atmosphere parameters (PPM): -100~+100ppm (step length 1 ppm)

※2) The atmosphere correction value will be calculated by the instrument according to the inputted temperature and pressure value.

6.2.1.2 Input Atmospheric Correction Value directly

Test the temperature and air pressure out, and get the Atmospheric Correction Value (PPM) from the formula of Atmospheric Correction.

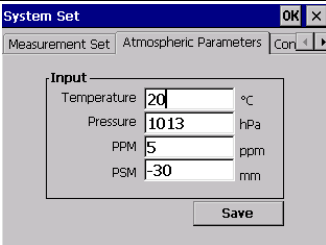
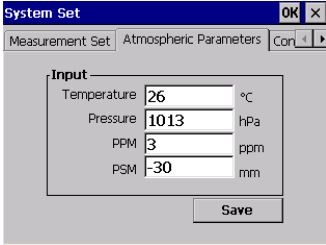
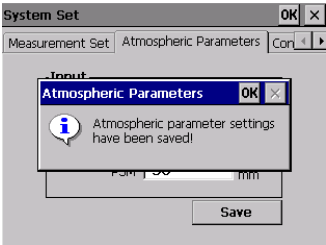
OPERATION STEPS	OPERATION	DISPLAY
<p>① In the menu of total station, click “Meas.Setup” and then click “Atmospheric Parameters”</p>	<p>“Meas.Setup” +“Atmospheric Parameters”</p>	
<p>② Delete the old PPM and input the new one</p>	<p>Input PPM Value</p>	
<p>③ Click [Save] to save the value.</p>	<p>[Save]</p>	
<p>※1)The inputting scope of Atmospheric parameters : -100 ~ +100 PPM(step length : 1PPM)</p>		

Atmospheric Correction value also can be set in star key (★)mode.

6.2.2 Atmospheric Refraction and Earth Curvature Correction

When calculating the horizontal distance and the height differences, the instrument will automatically correct the effect of atmosphere refraction and the earth curvature the correction.

The atmosphere refraction and the earth curvature are calculated by the formulas as follows:

Corrected Horizontal Distance:

$$D = S * [\cos\alpha + \sin\alpha * S * \cos\alpha(K-2) / 2Re]$$

Corrected Height Differentia:

$$H = S * [\sin\alpha + \cos\alpha * S * \cos\alpha(1-K) / 2Re]$$

If the correction of atmosphere refraction and the earth curvature are neglected, the calculation formula of horizontal distance and the height differentia are:

$$D = S \cdot \cos\alpha$$

$$H = S \cdot \sin\alpha$$

In formula: $K=0.14$ Atmosphere Refraction Modulus

$Re=6370 \text{ km}$ The Earth Curvature Radius

$\alpha(\text{or}\beta)$ The Vertical Angle Calculated From Horizontal Plane (Vertical Angle)

S Oblique Distance





NOTE: The atmosphere refraction modulus of this instrument has been set as: $K=0.14$.it also can be set as : $K=0.2$,or be set shut (0 VALUE).(refer to “14”SYSTEM SETTINGS).

6.2.3 Setting Target Type

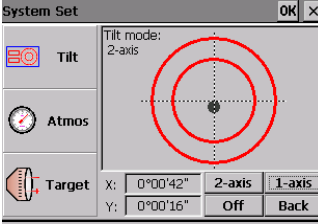
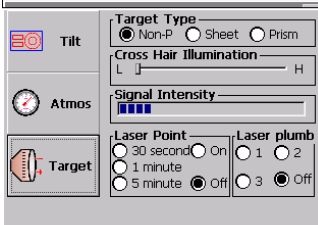
N7/N9 Series Total Stations can set options of visible Laser EDM and Invisible Laser EDM, as well as reflector with prism, non-prism, and reflective sheet. User can set them according to the requirements of the job.

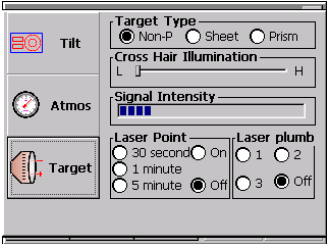
You can set Target Type in star key (★)model.

OPERATIONSTEPS	OPERATION	DISPLAY
<p>① Press [★] on keypad to open the system set window.</p>	<p>[★]</p>	
<p>② Click [Target] to set the type.</p>	<p>[Target]</p>	

<p>③ Use stylus to choose the type of the target.</p>		
<p>④ Press [ENT] to quit.</p>	<p>[ENT]</p>	
<p>※ Instruction of the target type:</p> <p> Non-P: measure with the visible red laser, no need to use prism. All of types of target are available for measure.</p> <p> Sheet: Use the sheet as target to measure. Prism: Use the prism as target to measure.</p> <p> Prism: Use the prism as the target to measure.</p>		

6.2.4 Setting the Prism Constant

Since the constants of prisms manufactured by different companies are different, the corresponding prism constant must be set. Once the prism constant is set, it would be kept even if the machine is turned off.

OPERATION STEPS	OPERATION	DISPLAY
-----------------	-----------	---------

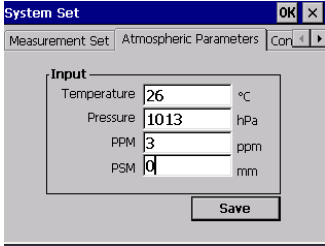
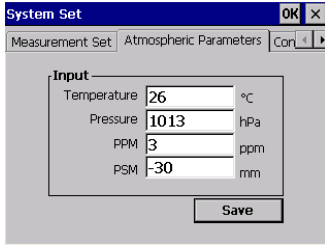
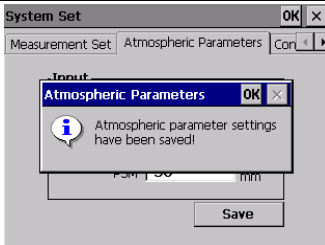
<p>① In the menu of total station, click “Meas.Setup” and then click “Atmospheric Parameters”</p>	<p>“Meas.Setup” + “Atmospheric Parameters”</p>	
<p>② Current Atmospheric Parameters display on the screen. Use stylus to move cursor to PSM input area, delete data and input new numbers. ※1)</p>	<p>Input Value</p>	
<p>③ Click [Save].</p>	<p>[Save]</p>	
<p>④ Click [OK] to</p>	<p>[OK]</p>	

save.		
※1) The scope of prism constant : -100mm~+100mm, Step Length 0.1mm		

You also can set Prism Constant in star key (★) mode.

6.2.5 Distance Measurement (Continuous Measurement)

Make sure the mode is Angle measurement.

See the Example in next page.

OPERATION STEPS	KEY	DISPLAY
① Sight at the center of prism.	Sight	
② Click [Dist] to enter distance measurement. The system start measuring according to EDM mode set last time.	[Dist]	

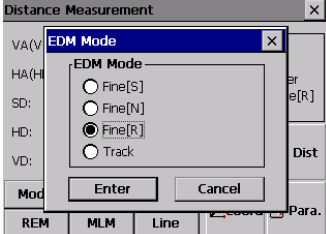
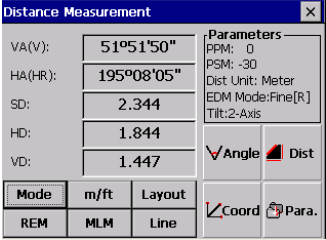
<p>③ Click [Mode] to enter EDM Mode setting. Here takes Fine[r] as example.</p>	<p>Mode</p>	
<p>④ The measure result displays. ※1)~ ※3)</p>		
<p>※1) To change measuring mode, click [Mode], set as step ※2) The result is shown with buzzer sound. ※3) Measurement may repeat automatically if the result is affected by atmospheric refraction etc. ※4) To return to Angle measurement mode, click "Angle" key.</p>		

6.2.6 Distance Measurement (Single/N-Time Measurement)

When the number of times for measurement is preset, the instrument measures the distance according to the specified number or times. The average result will be displayed.

When presetting the number of times as 1, it does not display the average distance because it is just single measurement; single measurement is default factory setting.

1) Example: Setting the number of times

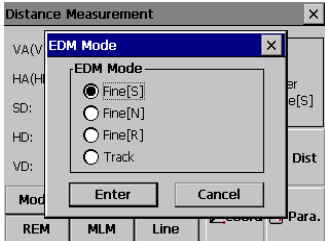
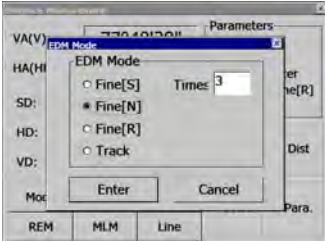
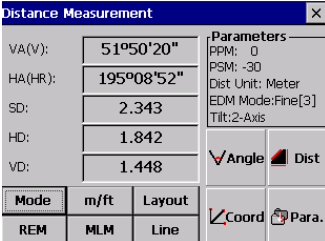
OPERATION STEPS	KEY	DISPLAY
<p>① In distance measuring Mode, click [Mode] to enter EDM Mode setting. System defaults as Fine[s].</p>	<p>[Mode]</p>	
<p>② Click Fine [N] or press [▲]/[▼], a Times column displays on the upper right screen. Input the times of N-time measurement.</p>	<p>[Fine[N]] Input times</p>	
<p>③ Click [Enter]. Sight the target, system start survey based on the setting set just now.</p>	<p>[Enter]</p>	
<p>※1) To return to Angle measurement mode, click “Angle” key.</p>		

6.2.7 Fine/Tracking Measurement Mode

Fine mode: This is the common distance measurement mode.

Tracking mode: This mode measures quickly. Use this mode for stakeout measurement. It is very useful for tracing the moving object or carrying out stake-out job.

Example:

OPERATION STEPS	KEY	DISPLAY
① Sight the center of prism.	Sight the prism	
② Click [Mode] to enter EDM Mode setting set it as Track.	[Mode]	

SOUTH

③Click [Enter]. Sight the target, system start survey based on the setting set just now.	[Enter]	<table border="1"><thead><tr><th colspan="3">Distance Measurement</th></tr></thead><tbody><tr><td>VA(V):</td><td>60°32'07"</td><td rowspan="5">Parameters PPM: 0 PSM: -30 Dist Unit: Meter EDM Mode:Track Tilt:2-Axis</td></tr><tr><td>HA(HR):</td><td>210°46'25"</td></tr><tr><td>SD:</td><td>2.767</td></tr><tr><td>HD:</td><td>2.409</td></tr><tr><td>VD:</td><td>1.361</td></tr><tr><td><input checked="" type="checkbox"/> Angle</td><td><input checked="" type="checkbox"/> Dist</td><td></td></tr><tr><td><input checked="" type="checkbox"/> Coord</td><td><input checked="" type="checkbox"/> Para.</td><td></td></tr><tr><td>Mode</td><td>m/ft</td><td>Layout</td></tr><tr><td>REM</td><td>MLM</td><td>Line</td></tr></tbody></table>	Distance Measurement			VA(V):	60°32'07"	Parameters PPM: 0 PSM: -30 Dist Unit: Meter EDM Mode:Track Tilt:2-Axis	HA(HR):	210°46'25"	SD:	2.767	HD:	2.409	VD:	1.361	<input checked="" type="checkbox"/> Angle	<input checked="" type="checkbox"/> Dist		<input checked="" type="checkbox"/> Coord	<input checked="" type="checkbox"/> Para.		Mode	m/ft	Layout	REM	MLM	Line
Distance Measurement																												
VA(V):	60°32'07"	Parameters PPM: 0 PSM: -30 Dist Unit: Meter EDM Mode:Track Tilt:2-Axis																										
HA(HR):	210°46'25"																											
SD:	2.767																											
HD:	2.409																											
VD:	1.361																											
<input checked="" type="checkbox"/> Angle	<input checked="" type="checkbox"/> Dist																											
<input checked="" type="checkbox"/> Coord	<input checked="" type="checkbox"/> Para.																											
Mode	m/ft	Layout																										
REM	MLM	Line																										

6.3 COORDINATE MEASUREMENT

6.3.1 Setting Coordinate Values of Occupied Point

Set the occupied point Coordinate according to coordinate origin, and the instrument automatically converts and displays the prism point Coordinate based on the origin and occupied point.

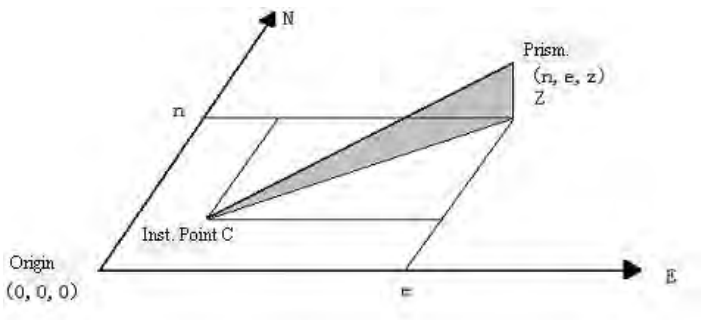

Example:

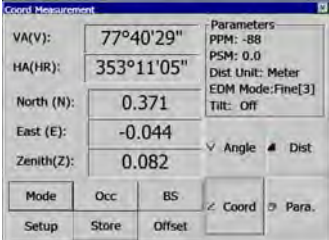
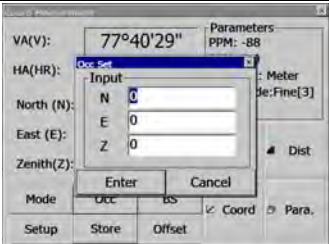
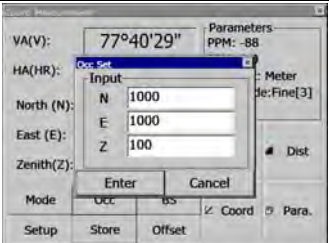
OPERATION STEPS	KEY	DISPLAY
<p>① Click [Coord] to enter into coordinate measurement.</p>	<p>[Coord]</p>	
<p>② Click [Occ] .</p>	<p>[Occ]</p>	
<p>③ Input coordinate of occupied point, after inputting one item, click [Enter] to move to the next item.</p>	<p>[Enter]</p>	

<p>④ After all inputting, click [Enter] to return to coordinate measurement screen.</p>	<p>[Enter]</p>	
---	----------------	--

6.3.2 Setting the Backsight Point

Example:

OPERATION STEPS	KEY	DISPLAY
<p>① Click [BS] to enter BS Setting.</p>	<p>[BS]</p>	
<p>② Input coordinates of backsight point. After inputting one item, click [Enter] to move to the next item.</p>	<p>[Enter]</p>	

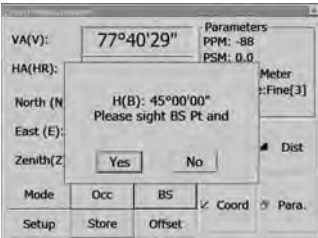
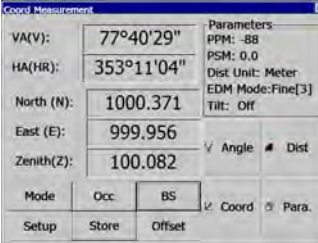
<p>③ After inputting, click [Enter]</p>	<p>[Enter]</p>	
<p>⑤ Sight at the backsight point, click [YES]. System sets the backsight azimuth and returns to Coordinate Measurement Screen. The screen displays the backsight azimuth set just now.</p>	<p>[Yes]</p>	

6.3.3 Setting the Instrument Height/ Prism Height

Measure the Coordinate by entering the instrument height / prism height, Coordinate of unknown point will be measured directly.

OPERATION STEPS	KEY	DISPLAY
-----------------	-----	---------

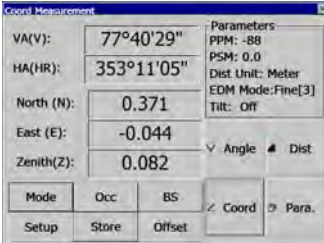
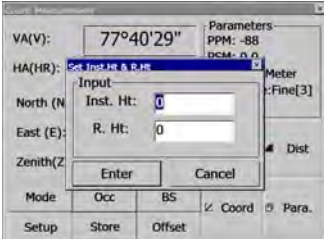
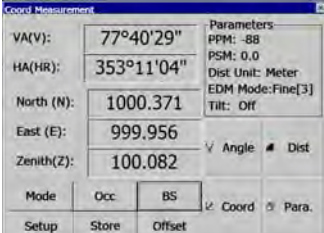
<p>① Click [Setup] to enter Set Inst.Ht&R.Ht function.</p>	<p>[Setup]</p>	
<p>② Input instrument height, and target height. After inputting one item, click [Enter] to move to the next item.</p>	<p>Input instrument height, and target height.</p>	
<p>③ After inputting all data, Click [Enter] to return to Coordinate Measurement Screen.</p>	<p>[Enter]</p>	

6.3.4 Operation of Coordinate Measurement

Measure the Coordinate by entering coordinate of occupied point, backsight azimuth, the instrument height and prism height, coordinate of unknown point will be measured directly.

- To set coordinate value of occupied point, see Section “6.3.1 Setting Coordinate Values of Occupied Point”.
- To set the instrument height and prism height, see Section “6.3.3 Setting of the Instrument Height/Prism Height”.
- The Coordinate of the unknown point are calculated as shown below and displays:
Coordinate of occupied point: (N0, E0, Z0)
Coordinate of the centre of prism ,originated from the centre point of the instrument: (n,e,z)
Coordinate of unknown point : (N1, E1, Z1)

$$N1 = N0 + n$$

$$E1 = E0 + e$$

$$Z1 = Z0 + \text{Inst.Ht} + z - \text{Prism} .$$

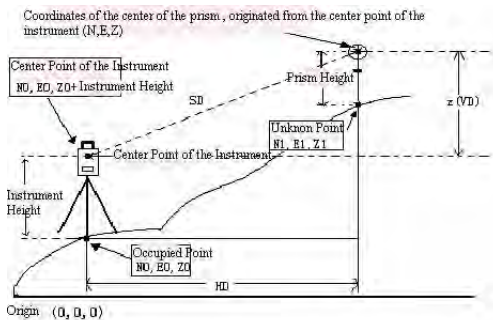

Example:

OPERATION STEPS	KEY	DISPLAY
<p>① Set coordinate values of occupied point and instrument / prism height ※1)</p> <p>② Set backsight azimuth. ※2)</p> <p>③ Collimate target. ※3)</p>		
<p>④ Click [Coord].</p> <p>Measurement ends and the result displays. ※4)</p>	[Coord]	
<p>※1) In case the coordinate of occupied point is not entered, then the coordinate of occupied point set last time would be used. The instrument height and the prism height will be the value you set last time.</p> <p>※2) Refer to Section “6.1.3 Horizontal Angle Reading Setting” or “6.3.2 Setting the Backsight Point”.</p> <p>※3) Click [Mode], the mode (SINGLE/N-TIME/REPEAT/TRACKING) changes.</p> <p>※4) To return to the normal angle or distance measuring mode, click [Angle]/[Dist].</p>		

7. APPLICATION PROGRAMS

7.1 LAYOUT

The difference between the measured distance and the preset distance is displayed.

The displayed value = Measured distance – Standard (Preset) distance

- This function enables the stake-out of Horizontal Distance (HD), Vertical Difference (VD) or Slope Distance (SD).

Example:

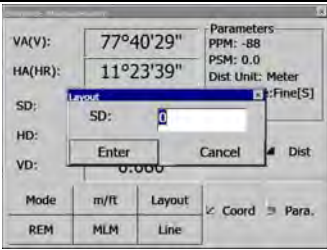
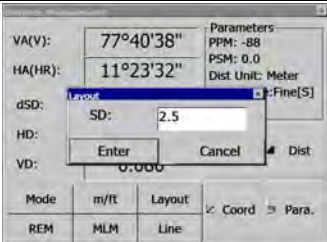
OPERATION STEPS	KEY	DISPLAY
<p>① Under the mode of Distance Measurement, click [Layout].</p>	<p>[Layout]</p>	
<p>② Select the distance measurement mode (SD/HD/VD) to be laid out. After inputting the data to be laid out, click [Enter] ※ 1)</p>		

③ Start setting out.

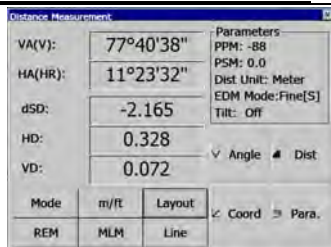

※1)A dialog box prompts to enter slope distance you want to layout, after entering click[Enter] to layout SD. To layout horizontal distance, input 0 in SD dialog box. Click[Enter], the HD box will prompt. After entering click [Enter] to layout HD. To layout height difference, input 0 in SD and HD box, and then the dialog box of VD to be staked out will prompt.

7.2 REMOTE ELEVATION MEASUREMENT (REM)

The Remote Elevation program calculates the vertical distance (height) of a remote object relatively to a prism and its height from a ground point (without a prism height). When using a prism height, the remote elevation measurement will start from the prism (reference point). If no prism height is used, the measurement will start from any reference point in which the vertical angle is established. In both procedures, the reference point should be perpendicular to the remote object.

7.2.1 Inputting Prism Height (h)

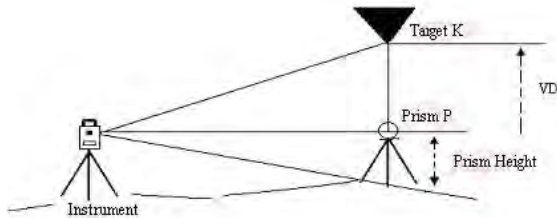

Example: (h=1.5m)

OPERATION STEPS	KEY	DISPLAY
<p>① In Distance Measurement, click[REM]to enter into REM function.</p>	<p>[REM]</p>	
<p>② As shown in the right graph, use stylus to click "WithR.Ht".</p>	<p>[With R.Ht]</p>	

SOUTH

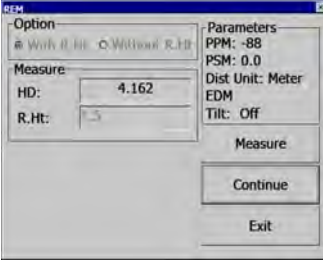
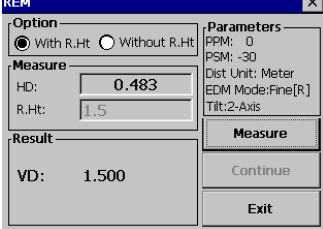
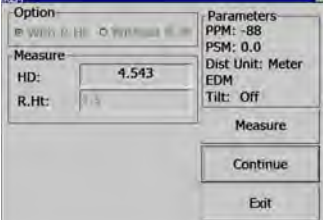
<p>③ Input prism height.</p>	<p>Input prism height</p>	
<p>④ Sight the prism center P.</p> <p>⑤ Click[Measure]to start measure.</p> <p>⑥ The HD between instrument and prism is displayed.</p>	<p>Sight the prism [Measure]</p>	
<p>⑦ Click[Continue],the prism position is entered.</p>	<p>[Continue]</p>	
<p>⑧ Sight target K. The Vertical Distance (HD) is displayed. ※1)</p>	<p>Sight K</p>	

※1) To quit REM, click[Exit].

7.2.2 without Inputting Prism Height

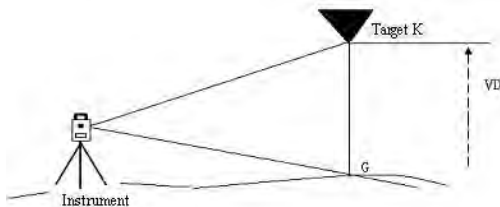

Example:

OPERATION STEPS	KEY	DISPLAY
<p>① Use stylus to click "Without R. Ht"</p>	<p>Without R.Ht</p>	<p>The screenshot shows a software interface with a blue title bar. On the left, under 'Option', there are two radio buttons: 'With R.Ht' (unselected) and 'Without R.Ht' (selected). Below this is a 'Measure' section with an 'HD:' label and an empty input field. On the right, under 'Parameters', the following values are listed: PPM: 4, PSM: 0.0, Dist Unit: Meter, EDM, and Tilt: Off. At the bottom right, there are three buttons: 'Measure', 'Continue', and 'Exit'.</p>

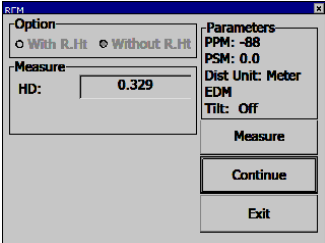
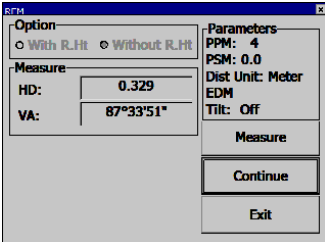
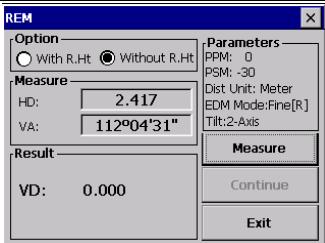
<p>② Sight prism center P.</p> <p>③ Click[Measure] to start survey.</p> <p>④ The HD between instrument and prism is displayed.</p>	<p>Sight prism</p> <p>Measure</p>	
<p>⑤ Click [Continue], The G point position is entered.</p>	<p>[Continue]</p>	
<p>⑥ Click [Continue].</p>	<p>[Continue]</p>	

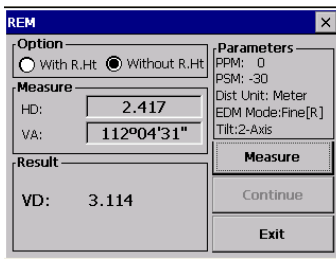
<p>⑦ Sight target K. The Vertical Distance (VD) is displayed. ※1)</p>	<p>Sight target</p>	
<p>※1) To quit REM, click [Exit].</p>		

7.3 MISSING LINE MEASUREMENT (MLM)

The Missing Line Measurement program computes the horizontal distance (dHD), slope distance (dSD) and vertical difference (dVD).

This program can accomplish this in two ways:

1. (A-B, A-C): Measurement A-B, A-C, A-D

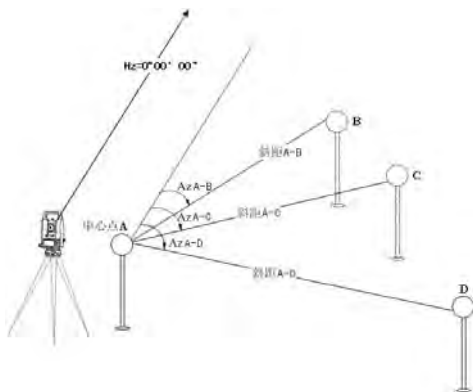

2. (A-B, B-C): Measurement A-B, B-C, C-D

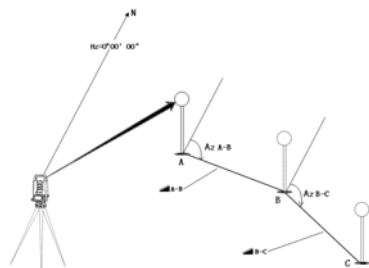

[EXAMPLE] 1. (A-B, A-C)

OPERATION STEPS	KEY	DISPLAY
<p>① In Distance Measurement, click[MLM]to enter into missing line measurement function</p>	<p>[MLM]</p>	
<p>② Use stylus to select A-B, A-C.</p>		

SOUTH

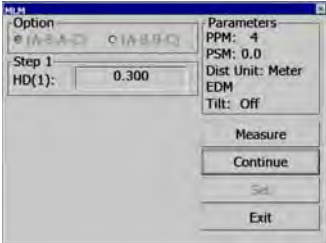
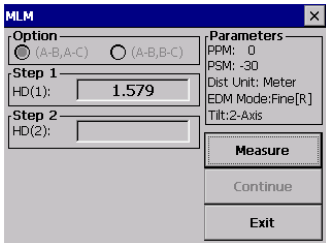
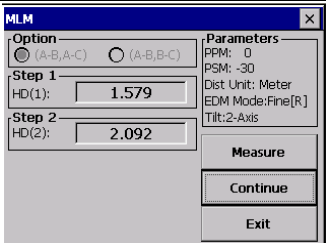
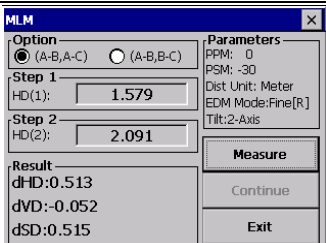
<p>③ Sight prism A, click [Measure]. The HD between instrument and prism A is displayed.</p>	<p>Measure</p>	
<p>④ Click [Continue].</p>	<p>Continue</p>	
<p>⑤ Sight prism B, Click[Measure]</p>	<p>[Measure]</p>	
<p>⑥ Click[Continue], The horizontal distance (dHD) height differential (dVD) and slope distance (dSD) between prism A and B display.</p>	<p>[Continue]</p>	

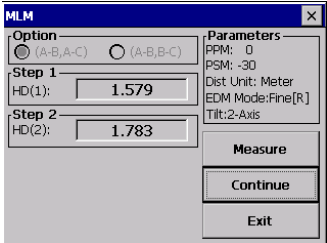
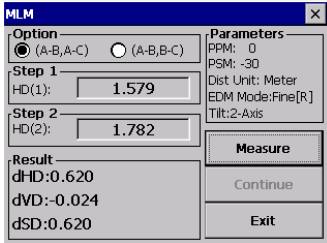
<p>⑦ To measure distance between point A and C, sight prism C and then click[Meas. After measuring, horizontal distance between the instrument and prism C displays.</p>	<p>[Measure]</p>	
<p>⑧ Click [Continue], the horizontal distance (dHD), height difference (dVD) and slope distance (dSD) between prism A and C displays.</p>	<p>[Continue]</p>	
<p>※1) Click[Exit] to return to main menu.</p>		

- The observation procedure of (A-B, B-C) is same as (A-B, A-C).

7.4 LINE MEASUREMENT (LINE)

The Line Measurement program allows the user to measure the height of an inaccessible object above a point. Both the inaccessible object and the point are located along an established base line. Two prisms, A and B, are set up apart from each other below the object to establish the base line. The horizontal distance is measured and set in the instrument for both prism A and B. The screen then

shows the vertical distance from prism A and B, the horizontal distance from the instrument to prism B, and the distance along the base line and the screen will display the vertical distance from prism A to that point, the horizontal distance for that point. Additionally, the vertical distance between two points on the base line, Point G and L in the diagram can be measured.

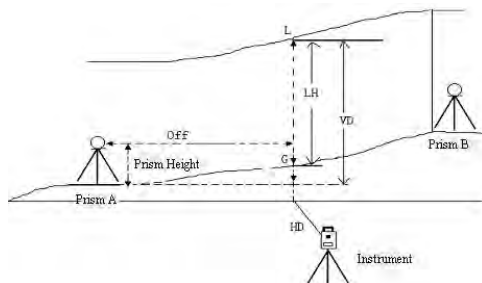

Example: Input of prism height

OPERATION STEPS	KEY	DISPLAY
<p>① In Distance Measurement, click [Line] to enter into line height measurement function</p>	<p>[Line]</p>	

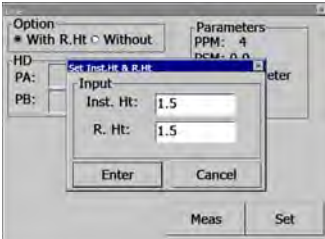
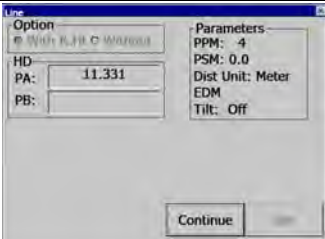
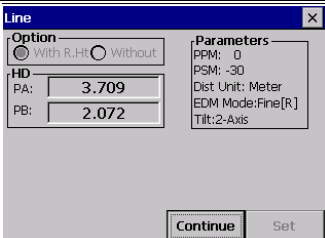
<p>② Use stylus select with R.H.</p>		
<p>③ Click[Set]to set instrument height and target height. After inputting, click[Enter].</p>	<p>[Set]</p>	
<p>④ Sight prism A, click[Meas] to start measure. After measuring, click[Continue].</p>	<p>[Meas]</p>	
<p>⑤ Sight prismB, click [Meas] to start distance measure.</p>	<p>[Meas]</p>	

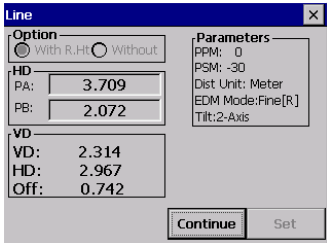
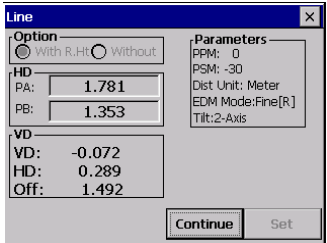
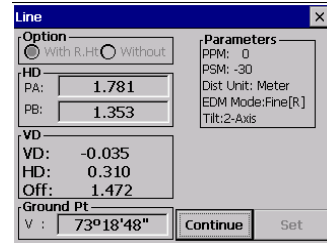
<p>⑥ After measuring click[Continue].</p>	<p>[Continue]</p>	
<p>⑦ Sight line point L, Measured data to the line point L is displayed.</p> <p>VD : Vertical distance</p> <p>HD: Horizontal distance from the instrument to L</p> <p>Off : Horizontal distance from A to L</p>		
<p>⑧ Click [Continue].</p> <p>This function is used when measuring the line height from the ground, OPERATIONAL STEPS:</p> <ul style="list-style-type: none"> ●Sight the point on the line before clicking [Next]. ●Don't move the horizontal tangent screw when setting ground point G 	<p>Continue</p>	

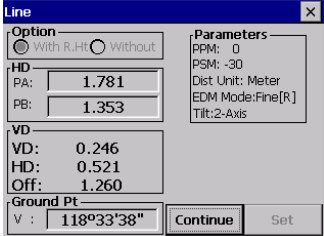
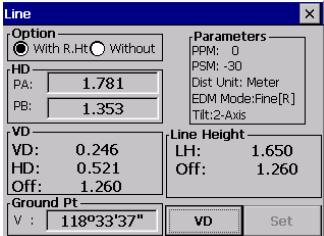
<p>⑨ Rotate the vertical tangent screw and sight at ground point G.</p>	<p>Sight at G</p>	
<p>⑩ Click[Next], line height LH (LH) and horizontal distance (Off) are displayed ※1)~※3)</p>	<p>[Continue]</p>	
<p>※1) To finish the measurement, press [ESC].</p> <p>※2) To return to operation step ⑦ click [VD].</p> <p>※3) The NEXT key is used when the ground point G is not clear and you would like to check another ground point G on the same vertical line.</p>		

7.5 TRAVERSE MEASUREMENT (RESTORE NEZ)

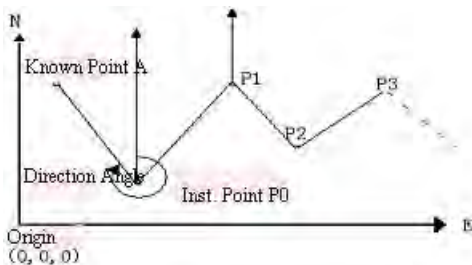

In this program the coordinate for the next point is stored in memory after the measurement is completed and accepted. The feature allows the user to occupy the next move-up point and use the previous occupied point for the backsight orientation. When occupying the next point and backsighting the original occupied point, the instrument will display the reverse angle for backsight orientation. If the occupied coordinate is not preset, zero (0,0,0) or the previous preset coordinate will be used for this program.



- Set the coordinate value of instrument point P0 and set the direction angle from P0 toward the known point A.

Example:

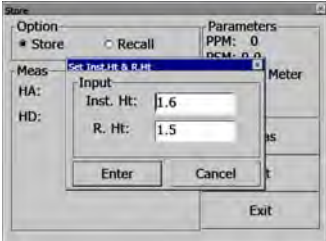
OPERATIONAL STEPS	KEY	DISPLAY
Under Coordinate Menu. ① Click[Store].	[Coord] [Store]	
② Use stylus select "Store"	[Store]	

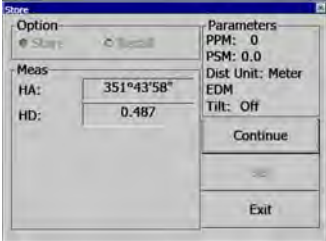
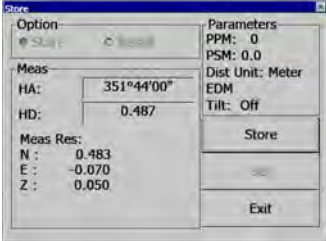
<p>③ Click[Set] to reset instrument height or prism height. After setting, click[Enter].</p>	<p>[Set]</p>	
<p>④ Collimate target p1 prism which the instrument moves. Click[Measure]to start survey.</p>	<p>[Meas]</p>	
<p>⑤ Click[Continue]. The coordinates of P1 displays at the bottom of screen.</p>	<p>[Continue]</p>	
<p>⑥ Click [Store]. Coordinate of P1 will be confirmed.The display returns to main menu. Power off and move instrument to P1 (Prism P1move to P0)</p>	<p>[Store]</p>	

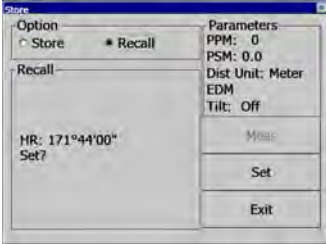
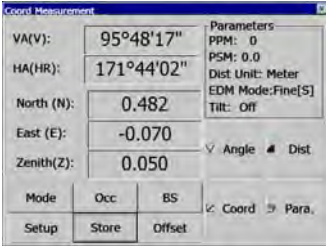
<p>⑦ After the instrument is set up at P1, power on and start coord Measurement. Select Store, use stylus to choose "Recall". Show as the right graph.</p>	<p>Recall</p>	
<p>Collimate the former instrument point P0, click [Set]. The coordinate at P1 and direction angle toward P0 is set. The display returns to main menu.</p>		
<p>⑨ Repeat the steps ①~⑧, as required.</p>		
<p>Note: To exit, click "Exit" or press "ESC" key.</p>		

7.6 OFFSET MEASUREMENT (OFFSET)

There are four offset measurement modes in the Offset Measurement.

1. Angle offset
2. Distance offset
3. Plane offset
4. Column offset

7.6.1 Angle Offset

This mode is useful when it is difficult to set up the prism directly, for example at the centre of a tree. Place the prism at the same horizontal distance from the instrument as that of point A0 to measure. To measure the Coordinate of the centre position, operate the offset measurement after setting the instrument height/prism height.

- When measuring coordinates of ground point A1: Set the instrument height/prism height.
- When measuring coordinates of ground point A0: Set the instrument height only.
(Set the prism height to 0)

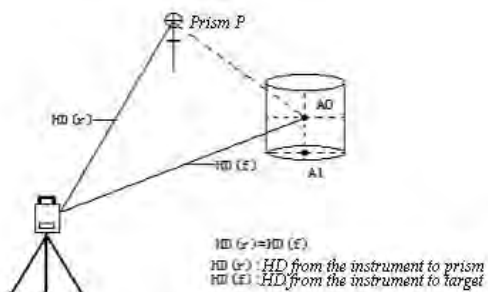

●In the Angle Offset Measurement Mode, there are two setting methods for the vertical angle.

- 1.Free vertical angle : The vertical angle will be changed by rotating telescope.
- 2.Hold vertical angle : The vertical angle will be locked and never changed by rotating telescope.

When sighting to A0, you can select one way, [Hold] is to fix vertical angle to the prism position. When you select [Free], SD (Slope Distance) and VD (Vertical Distance) will be changed according to the movement of telescope.

Example:

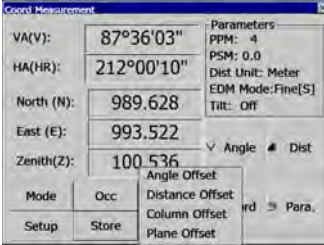
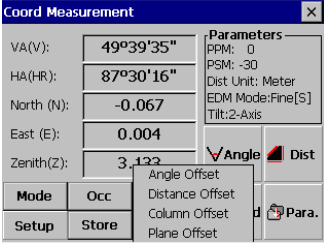
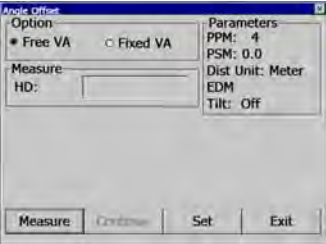
OPERATIONAL STEPS	KEY	DISPLAY
<p>① Click[Offset].</p>	<p>[Offset]</p>	
<p>② In the prompted dialogue box click[Angle Offset] to enter into angle offset measurement.</p> <p>③ Use the stylus to select “Free VA” (or “Fixed VA”) to start angle offset measurement.</p>	<p>Angle Offset</p>	
<p>④ Collimate prism P, click[Measure]to start.</p>	<p>Sight prism P Measure</p>	

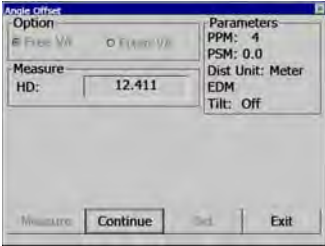
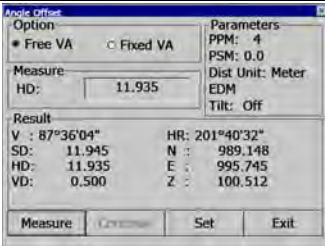
<p>⑤ Use horizontal clamp screw and horizontal tangent to sight target A0.</p>	<p>Collimate A0</p>	
<p>⑥ Click[Continue] The slope distance, horizontal distance and height differential and coordinate from instrument to point A0 will be shown ※1), ※2)</p>	<p>[Continue]</p>	
<p>※1) To set instrument height or target height, click [Set]. ※2) Click [Exit] to quit.</p>		

- Set Inst. Height/Prism Height before starting offset measurement.
- to set the coordinate of occupied point, refer to“6.3.1 Setting Coordinate Values of Occupied Point”.

7.6.2 Distance Offset

The measurement of a place apart from a prism is possible by inputting offset horizontal distance of front and back/right and left.

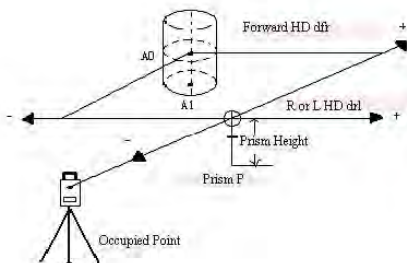

- When measuring Coordinate of ground point A1: Set the instrument height / prism height.
- When measuring Coordinate of ground point A1: Set the instrument height only (Set the prism height to 0).
- Setting the coordinate of occupied point, refer to “6.3.1 Setting Coordinate Values of Occupied Point”.

OPERATIONAL STEPS	KEY	DISPLAY
<p>① In Offset dialog box, click [Distance Offset] to enter into Dist. Offset.</p>	<p>[Distance Offset]</p>	

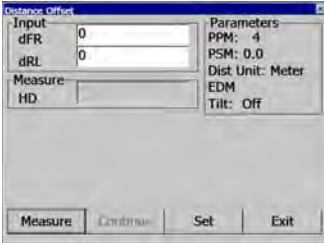
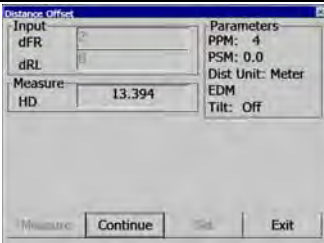
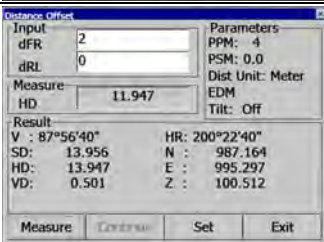
<p>② Move stylus to “Input”, enter the offset distance.</p> <p>When each value is inputted, use stylus to move the next item.</p>		
<p>③ After inputting “dRL”, sight the prism, click [Measure] to start measure.</p>	<p>[Measure]</p>	
<p>④ Click [Continue], the corrected measure result displays, as shown in the right picture. ※1), ※2)</p>	<p>[Continue]</p>	
<p>※1) To set instrument height or target height, click [Set].</p> <p>※2) Click [Exit] to quit.</p>		

7.6.3 Column Offset

If it is possible to measure circumscription point (P1) of column directly, the distance to the center of the column (P0), coordinate and direction angle can be calculated by measured circumscription points (P2) and (P3).

The direction angle of the center of the column is 1/2 of total direction angle of circumscription points (P2) and (P3).

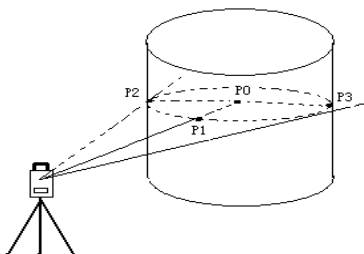

●Setting the coordinate of occupied point , refer to“6.3.1 Setting Coordinate Values of Occupied Point ”.

Example:

OPERATIONAL STEPS	KEY	DISPLAY
<p>① In Offset dialog box, click [Column Offset]to enter into Column Offset measurement.</p>	<p>[Column Offset]</p>	

SOUTH

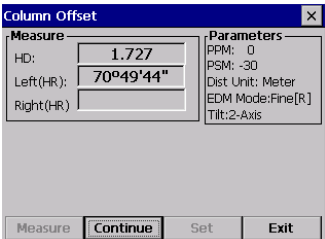
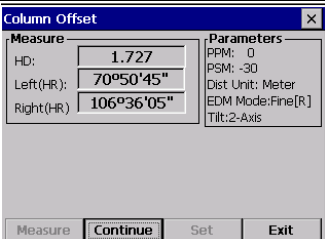
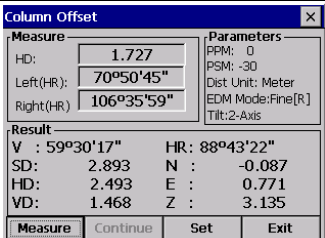
<p>② Collimate the center of the column (P1) and click[Measure]to measure. After measuring, click[Continue].</p>	<p>[Measure]</p>	
<p>③ Collimate the point (P2) on the left side, as shown in the right graph. Click[Continue].</p>	<p>[Continue]</p>	
<p>④ Collimate the right side of the column (P3)</p>		
<p>⑤ Click[Continue], the distance between the instrument and center of the column (P0) will be calculated and displayed ※1), ※2)</p>	<p>[Continue]</p>	

SOUTH

- ※1) To set instrument height or target height, click [Set].
- ※2) Click [Exit] to quit.

7.6.4 Plane Offset

Measurement will be taken for the place where direct measuring can not be done.

For example distance or coordinate measuring for an edge of a plane.

Three random target points (P1, P2, P3) on a plane will be measured at first in the Plane Offset measurement to determine the measured plane. Collimate the target point (P0) then the instrument calculates and displays coordinate and distance value of cross point between collimation axis and of the plane.

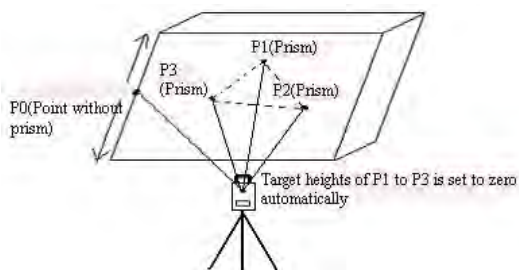

- Setting the coordinate of occupied point, refer to“6.3.1 Setting Coordinate Values of Occupied Point”.

Example:

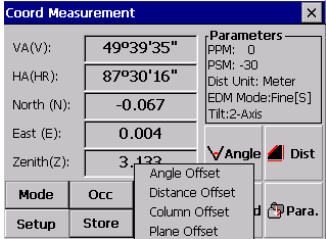
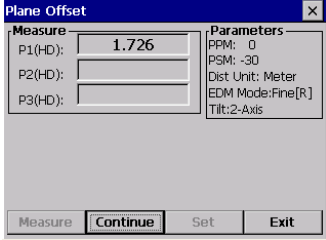
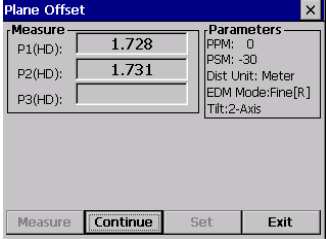
OPERATIONAL STEPS	KEY	DISPLAY
<p>① In Offset dialog box, click [Plane Offset] to enter into Plane Offset measurement.</p>	<p>[Plane Offset]</p>	
<p>② Sight prism P1, click [Measure] to start measure. Then click [Continue].</p>	<p>[Measure] [Continue]</p>	
<p>③ Measure the points P2, Click [Measure] to start measure. Then click [Continue].</p>	<p>[Measure] [Continue]</p>	

SOUTH

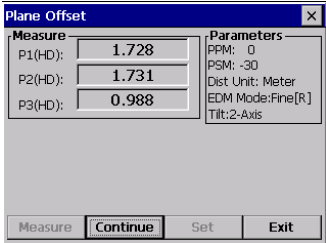
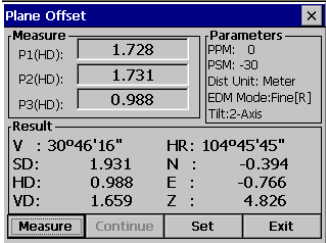
<p>④ Sight prism P3, Click[Measure]to start measure.</p>	<p>[Measure]</p>	
<p>⑤ Click[Continue] to calculate and display coordinate and distance value of cross point between collimation axis and of the plane. ※1)</p>	<p>[Continue]</p>	
<p>※1) To set instrument height or target height, click [Set].</p>		

- In case the calculation of plane was not successful by the measured three points, error displays. Start measuring over again from the first point.
- Error will be displayed when collimated to the direction which does not cross with the determined plane.

7.7 PARAMETERS SETTING

In basic survey, some parameters can be set.

Communication Parameters

Factory default settings are indicated with underlines>.

Menu	Selecting Item	Contents
1. Baud Rate	From 1200 to 115200 optional	Select the baud rate
2. Data bit	7 / 8	Select the data bit
3. Stop Bit	1 / 2	Select the stop bit.
4. Check Mode	None/Odd/Even	Select the parity bit.
5. ACK/NAK	Yes /No	When communicating to an external device, the protocol for handshaking can omit the [ACK] coming from the external device so data is not send again. Yes: Omit the [ACK] No: Standard

Other Parameters

Menu	Selecting Item	Contents
1. Coord. Ranking	NEZ/ENZ	Select the display format in the coordinate measurement mode for NEZ or ENZ
2. Occ Save	0 Set/Save	Select whether to save coordinate of occupied point or 0 Set.

3.Angle Unit	Deg/Gon/Mil	Select degree (360°) , gon (400 G) or mil (6400 M) for the measuring angle unit to be shown on the display
4.Distance Unit	Meter/Int.Feet/U. S Feet	Select the distance measuring unit.

Example:

OPERATIONAL STEPS	KEY	DISPLAY
① In the main menu of basic survey, click[Para.]to enter into Parameter Setting.	[Para.]	
② Use stylus to select items.		

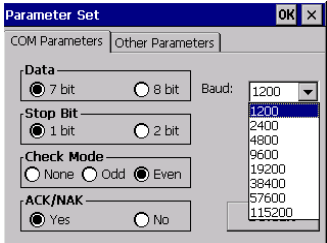
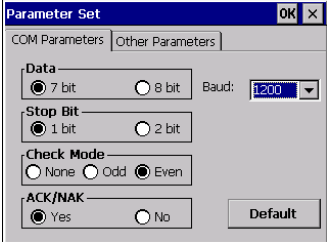
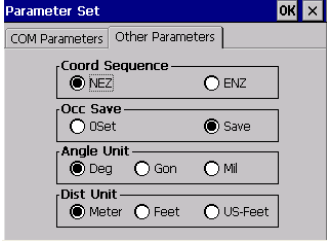
<p>③ Click the “▼” beside “Baud”, select the baudrate you need.</p>	<p>[▼]</p>	
<p>④ To use the default communication parameters, click [Default].</p>	<p>[Default]</p>	
<p>⑤ To set other parameters, click [Other Parameter]. Set as the same method.</p>	<p>[OtherParameter]</p>	
<p>⑥ After setting, click [OK] to quit. The display returns to basic survey main menu.</p>	<p>[OK]</p>	

8. START STANDARD SURVEYING PROGRAM

In Total station main menu, click "Std Survey" to enter standard surveying program. The screen displays as follows:

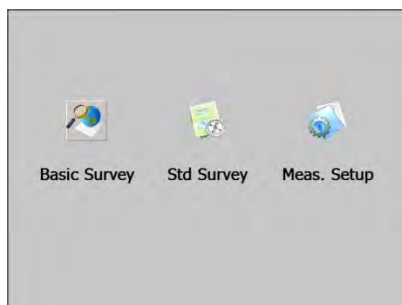

- Multiple Job Files

Standard Surveying program uses different files (with Job name) for raw data, coordinates and character strings. The job is given alphanumeric names. You may have many jobs

in the system. You may create a new job for storing data, or you may open an existing job for data storage. You are also allowed to delete job files.

- Traverse & Topographic Recording Sequences

Backsight and front sight observation options allow user to record traverses or sets of multiple observations in any sequence. Multiple observations of front-sights and backsights are averaged dynamically.

A side shot option allows data collection for topographic surveys. Traverse and topographic collection may be combined.

- Offsets

A single offset option is activated by a function key and allows manual entry of perpendicular offsets, or calculated offsets, including remote elevation from a second angle reading.

- Point Coordinate and String Generation

Coordinates are generated in real-time with optional storage. Stored coordinates are recalled at occupied stations and used for back bearing calculation.

- Horizontal Circle Setting

Backsight bearing may be set on the instrument from calculated coordinates or manual input.

- Control point Coordinate Library

Every control point library is accessible by all jobs for storage of frequently used coordinates. Control point file may be entered manually, or uploaded from computer.

- Point Code Library

Point codes may be selected from the library file.

- Edit and Delete Data

Raw data, point coordinates, control point coordinates and codes may be edited and deleted in the total station.

- Download to Serial Port

Raw data, coordinates can be sent to a computer by using a serial cable.

- Upload Point Code from Serial Port

The point code of total station may be created by uploading codes from a computer.

- Upload Roads Design data from serial port

Horizontal alignment data, vertical alignment data and cross section data for Alignment lay out can be uploaded from serial port.

- Point Setting-Out

The standard settingout program calculates bearing and distance, displays offsets from occupied point to lay-out point after each measurement. Coordinates of set-out points can be saved and differences downloaded in the fill-cut files.

Note that the scale factor defined under the SETUP will be used in the calculation of setting out distances.

- Strings Setting Out

Setting out of points by string (point code) allows the setting out of points on a line created in design software.

- Road Setting Out

Two options allow the setting out of points by chainage and offset from a road

alignment. Refer to Road Alignment.

- **Traverse Adjustment**

The Bowditch adjustment method is used to adjust a recorded traverse. The traverse is defined by entering start and end points and the intermediate points are determined from foresight observations.

- **Resection**

Calculate coordinates by known points. The method of calculation is depending on the data available. Either two points with angles and distances, or three points with angles only are required. Where more than three points and up to maximum of 10 points are available the least squares method is used.

Note that the scale factor defined under the SETUP function will be used in the calculation.

- **Occupied Point Elevate Calculation**

Calculate the occupied point by single observation to a known point.

- **Intersections**

Coordinates calculate from two known points, with either bearings or distances.

- **Inverse**

Calculate the bearing and distance between 2 known points, Note that the scale factor defined under the MENU function will be used in the calculation of distances.

- Area Calculation

Calculate the area of points by Pcode.

- Radiation

Coordinates of a point can be computed by entering bearing and distance.

- Missing Line measurement

The slope distance, horizontal distance and vertical distance between two points can be computed.

- Batter boards

It sets out the construct area of building. If two points cannot be set out, a batter board can be placed in the vicinity. The intersection point of the line connecting two set out points and the batter board can be found.

- Tape Dimension

Tape dimension is a program which integrates surveying using a total station and a measuring tape. This program is especially useful when a quick survey of an object is required.

9. PROJECT

In standard survey menu, click [Project].

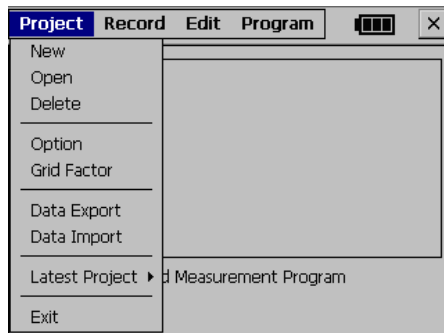

This menu allows following functions be performed:

- (1) Create, open, delete job file
- (2) Setting job option
- (3) Set grid factor
- (4) Data export/import

Standard measuring program require that every time measuring you must create a job file name, if not, system will create a default file name (default) automatically. All the measuring results will be saved in this file.

9.1 CREATE NEW PROJECT

Create a new project file. A job name has a maximum of 15 characters and should be made up from the letters A-Z,

numbers 0-9 and the minus sign (`_# $ @ % + -`), but the first character cannot be a

space.

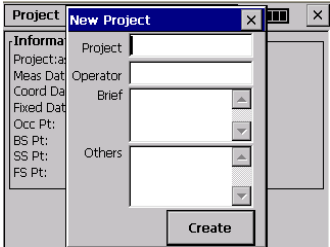
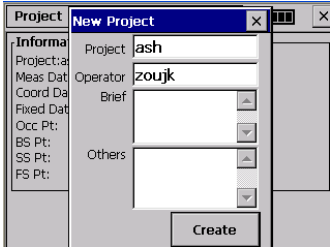
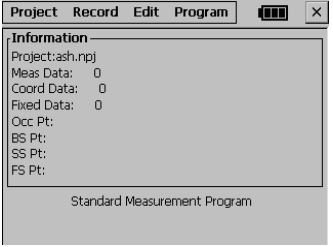
OPERATION STEPS	KEY	DISPLAY
<p>① In [Project] menu, click [New].</p>	<p>[New]</p>	
<p>② In the prompt dialog box, enter name of project, operator, and brief information. After inputting one item, use stylus to click the next item. ※ 1)</p>	<p>Enter information</p>	
<p>③ Inputting all, click [Create] to save. The new created project is defaulted as current project. The system return to standard survey main menu. ※ 2), ※3)</p>	<p>[Create]</p>	

※1) Project: All the measurement data will be stored in this file.

Operator: Operator's name (Can be default).

Brief: Brief information of the project. (Can be default)

Other : The operator can enter other information, such as instrument model.(Can be default)

※2) Press [ESC] key to exit the screen without saving the settings.

※3) If the project exists, the system prompts "Project are the same!" So, select OPEN option to see a list of current jobs before creating the new job if you are not sure which jobs currently exist.

9.2 OPEN PROJECT

Example:

OPERATION STEPS	KEY	DISPLAY
<p>① In [Project] menu, , Click[Open] or press [▲]/[▼] to select. The screen lists all jobs in internal memory.</p>	<p>[Open] [▲]/[▼]</p>	

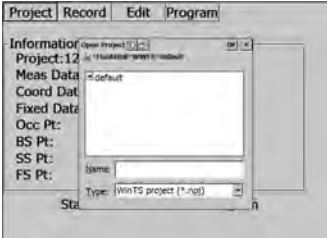
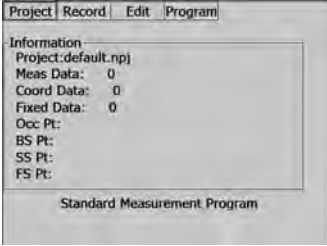
<p>② Double click to open the project, or input project name in the Name field.</p>		
<p>③ In the prompt dialog box, double click project name to open the project. All the measurement data will be stored in this file. The display returns to standard survey main menu.※1)</p>		
<p>※1) Press [ESC] to quit and return to last screen standard survey main menu.</p>		

9.3 DELETE PROJECT

Example

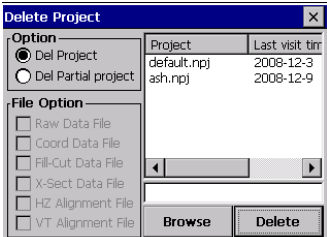
OPERATIONAL STEPS	KEY	DISPLAY
<p>① In [Project] menu, Click[Delete] or press [▲]/[▼] to select. The screen shows as the right graph.</p>	<p>[Delete]</p>	

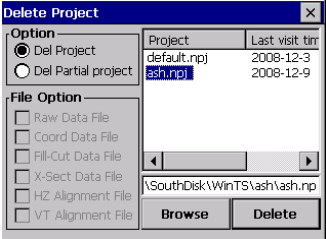
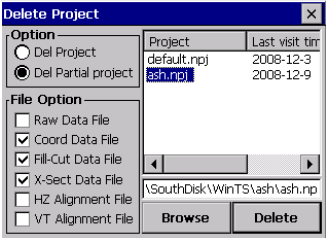
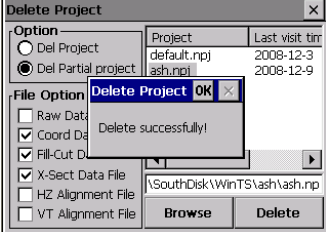
<p>② Double click the project you want to delete.</p> <p>The system defaults to delete all projects. To delete some data of the project, click “Delete Files” and then choose the data files need to delete in the File Option. ※1)</p>		 <p>Delete some files:</p> 
<p>③ Click[Delete]. The system shows”Delete successfully!”</p> <p>※2)~※3)</p>	<p>[Delete]</p>	
<p>※1)Delete all projects: Delete all content of the selected job.</p> <p>※2) Current project can't be deleted.</p> <p>※3)Click[Browse]to view project in internal memory.</p>		

9.4 PROJECT OPTION

OPERATIONAL STEPS	KEY	DISPLAY
<p>① In [Project] menu, click[Option](or press [▲]/[▼] to select), the screens as the right graph.</p>	<p>[Option]</p>	
<p>② Click each item to set. Click [Set] to return.</p>	<p>[Set]</p>	

Options:

Fixed File: Set the fixed point [On] or [Off].

If it is set as [On], when the fixed point file will be scanned for coordinates before prompting for the coordinates. When the same point number is saved in coordinate database or fixed database. The data in [coordinate data] will be called up.

2) If the station file option is OFF, the fixed point file is not searched.

Coord. Display: Set whether to display coordinate of NEZ during measurement.

Coord. Transform: Set whether to calculate and save coordinate.

If set as [On], when the measuring mode is H/V/SD or H/HD/VD, the coordinates will be calculated and saved automatically.

2) If set as [Off], the calculated coordinate will not be saved.

[Note]: In adjusting traverse, to save coordinate or set the calculated bearing angle into instrument, this option should be set to ON.

Layout Save : The setting of storing layout point coordinates, when the coordinates are saved, each layout point with designed coordinates and layout coordinates and cut or fill

height will be listed.

※Note that System Setting apply to all jobs, when it is changed, all jobs will be affected.

9.5 GRID FACTOR

Measured horizontal distance is multiplied by the scale factor in coordinate calculation. The raw data is not altered by the scale factor. Enter the scale factor and the mean elevation into screen, the downloaded raw data will contain a scale factor record. The following grid factor is used to calculate coordinates.

Calculation Formula:

$$1. \text{ HEIGHT FACTOR} = \frac{R}{R + ELEV}$$

R : The average radius of the earth

ELEV: The height of the mean sea level

2. SCALE FACTOR

Scale factor: the scale on the measurement station

GRID FACTOR

Grid factor = height factor × scale factor

Distance Calculation

1. GRID DISTANCE

HDg = HD × Grid factor

HDg: Grid distance

HD : Ground distance

2. GROUND DISTANCE

$$HD = \frac{HDg}{Grid}$$

Enter the scale factor and elevation.

Example:

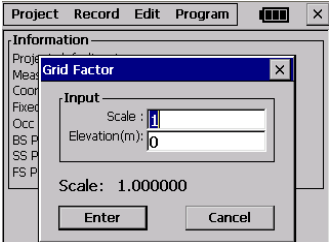
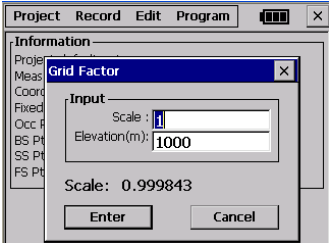
OPERATIONAL STEPS	KEY	DISPLAY
<p>① In [Project] menu, click [Grid Factor](or press [▲]/[▼] to select), the screen displays as the right graph.</p>	<p>[Grid Factor]</p>	 <p>The screenshot shows a software interface with a menu bar (Project, Record, Edit, Program) and a toolbar. A dialog box titled 'Grid Factor' is open, containing an 'Input' section with two text fields: 'Scale' (containing '1') and 'Elevation(m)' (containing '0'). Below the fields, the text 'Scale: 1.000000' is displayed. At the bottom of the dialog are 'Enter' and 'Cancel' buttons.</p>
<p>② Input the Scale and Elevation.</p>		 <p>The screenshot shows the same software interface as above. The 'Grid Factor' dialog box now shows 'Scale' (containing '1') and 'Elevation(m)' (containing '1000'). Below the fields, the text 'Scale: 0.999843' is displayed. The 'Enter' and 'Cancel' buttons remain at the bottom.</p>

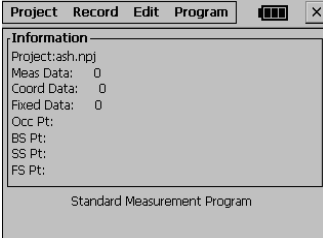
<p>③ The system calculates the grid factor. Click[Enter]. The display returns to standard survey main menu.</p>	<p>[Enter]</p>	
---	----------------	---



Note:1. Inputting range of scale:0.990000 ~ 1.010000. The default value: 1.00000

2. Inputting range of average altitude: -9999~9999The default value: 0

10. DATA EXPORT/IMPORT

10.1 DATA EXPORT

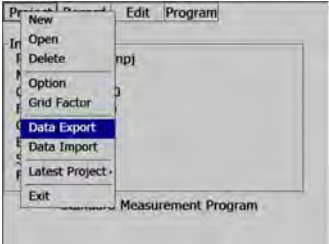
Measuring data coordinate and data of dig/fill, cross section may be exported to specified location.

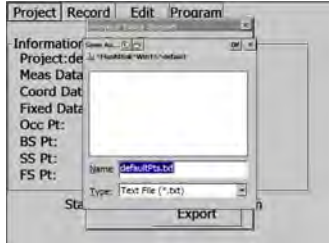
OPERATIONAL STEPS	KEY	DISPLAY
<p>① In project menu, click[Data Export].</p>	<p>[Data Export]</p>	
<p>② In the prompt dialog, click the data you want to export. Click[Export].</p>	<p>[Export]</p>	
<p>③ Select the place to save export data Input file name in the Name field.</p>		

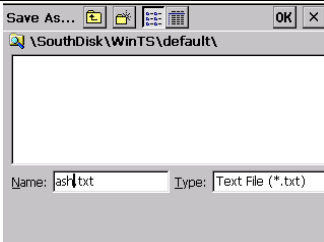
<p>④ Click[OK], then data is export to appointed position. And the display returns to standard survey main menus.</p>	<p>[OK]</p>	
---	-------------	---

SD CARD STORAGE:

N7/N9 allow surveyors to restore data into SD card.

Export the data you need to the disk inside of the total station first. System will save the result in TXT form. Plug in the SD card, and then you could find that icon of SD card in N7 /N9 system. Copy the file you need to SD card and disconnect it from total station.

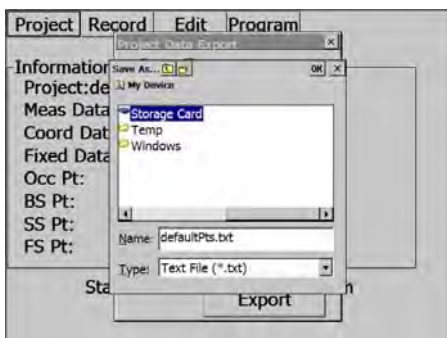

SOFTWARE EXPORT

Export the project you need to the disk inside of the total station first. System will save the result in TXT form. Then connect the N7/N9 total station to computer with

the USB cable after checking that if there Windows Mobile Device Center software has already been installed. Windows Mobile Device Center will show as follow:



At same time this icon will appear in your My computer.





Now you should find the TXT form file in Mobile Device and copy them to your PC disk. The process is completed.

10.2 DATA IMPORT

Coordinate files for setout, fixed point and code library files, alignments and cross section files for setout may be uploaded from a computer to the total station, then import to the project.

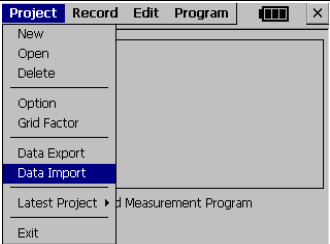
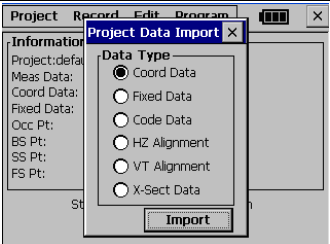
Example:

OPERATION STEPS	KEY	DISPLAY
<p>① In Project menu, click [Data Import].</p>	<p>[Data Import]</p>	 <p>The screenshot shows a software menu titled 'Project' with options: New, Open, Delete, Option, Grid Factor, Data Export, Data Import (highlighted), Latest Project, Measurement Program, and Exit.</p>
<p>② Select the data type you need to import, and click [Import]. ※ 1)</p>	<p>[Import]</p>	 <p>The screenshot shows a 'Data Type' dialog box with radio button options: Coord Data (selected), Fixed Data, Code Data, HZ Alignment, VT Alignment, and X-Sect Data. An 'Import' button is at the bottom.</p>

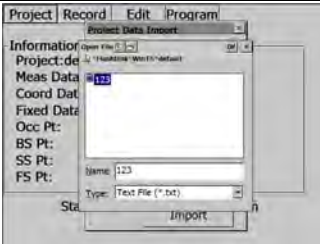
<p>③ The imported file is found.</p>		
<p>④ Click [OK], data is imported to appointed position and return to standard survey main menu.</p>	<p>[OK]</p>	
<p>※1)HZ Alignment: Upload a horizontal alignment for road design layout. Data format please refer to appendix A. There is only one start point can be existed in a block of horizontal alignment data; otherwise it may cause some mistakes.</p> <p>VT Alignment: Upload a vertical alignment for road alignment layout. Data format is described in Appendix A.</p> <p>X-Sect Data: upload a design cross section file for road design layout: The uploaded cross sections cannot be edited nor downloaded. Data format is described in Appendix A.</p>		

11. RECORD MEASUREMENT DATA

The RECORD menu is mainly used for collecting and recording raw data. It allows setting occupied point and backsight bearing, start backsight observation, foresight observation; sideshot observation and cross section observation. In standard survey main menu, click [Record]

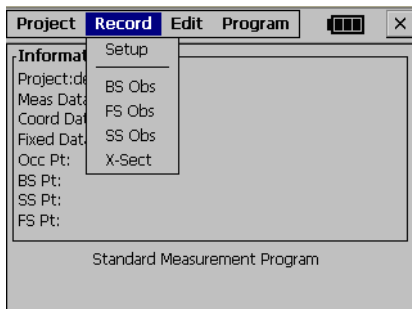

11.1 SETTING OCCUPIED POINT AND BACKSIGHT POINT

Example:

OPERATIONAL STEPS	KEY	DISPLAY
① In [Record] menu, click [Setup] ※1)	[Setup]	

② In "Occ PT" input the point name. Click [Info].

A: The system will start searching function. If the point name doesn't exist in internal memory, system will prompt to input coordinate As shown in the right graph.

B: If the point name exists in internal memory, system will call up the point automatically and display on the screen.

A:

B:

C:



Pt	Code	North
2		1000.000
3	kzd	986.457

Buttons: Search, Start, End, Load

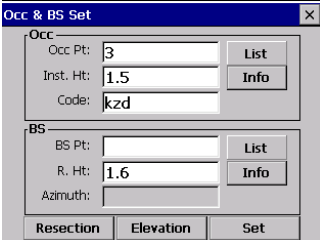
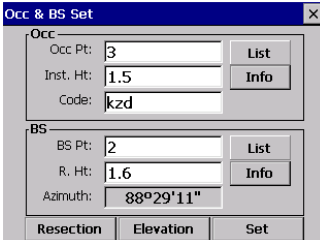
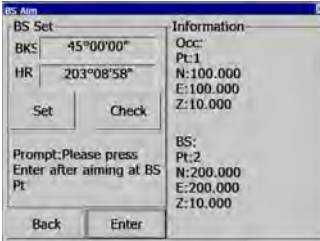
<p>③ Input the backsight point.</p>		
<p>④ The system calculates the azimuth.</p>		
<p>⑤ Click [Set] to enter into BS Set function.</p> <p>Bks: Bearing calculated by system or entered manually.</p> <p>HR: Current horizontal azimuth.</p>	<p>[Set]</p>	

⑥

A: If click [Set], the HR displays as the azimuth.

B:

If click [Check], backsight point coordinate will be checked by measuring the slope distance of backsight point.

C:

If click [Enter], the current horizontal angle is recorded as the initial backsight direction, and use for coordinate calculation.

A:

The screenshot shows the 'BS Set' screen with the following data:

BS Set	Information
BKS: 45°00'00"	Occ:
HR: 203°08'58"	Pt:1
Set	N:100.000
Check	E:100.000
	Z:10.000
Prompt: Please press	BS:
Enter after aiming at BS	Pt:2
Pt	N:200.000
Back	E:200.000
Enter	Z:10.000

B:

The screenshot shows the 'BS Set' screen with the following data:

BS Set	Information
BKS: 45°00'00"	Occ:
HR: 203°08'58"	Pt:1
Set	N:100.000
Check	E:100.000
	Z:10.000
Prompt: Please press	BS:
Enter after aiming at BS	Pt:2
Pt	N:200.000
Back	E:200.000
Enter	Z:10.000

C:

The screenshot shows the 'BS Set' screen with the following data:

BS Set	Information
BKS: 45°00'00"	Occ:
HR: 203°08'58"	Pt:1
Set	N:100.000
Check	E:100.000
	Z:10.000
Prompt: Please press	BS:
Enter after aiming at BS	Pt:2
Pt	N:200.000
Back	E:200.000
Enter	Z:10.000

⑦Click [Enter] to finish setting BS point and return to standard survey main menu.	[Enter]	
※1) Resection: The resection function key which is used to calculate the occupied point coordinate. Elevation: The function key for measuring the elevation of a point Details see “11.1.1Resection” and “11.1.2Elevation of Occupied Point”		

※**Note:** If the point exists both in the coordinate data library and fixed data library, then data from coordinatedata library will be used.

11.1.1Resection

If the coordinates of an occupied point are unknown, a resection can be performed to calculate these coordinates. A resection involves the measurements from an occupied point to several other known points. It is possible to perform a resection by measuring angles and distances or by measuring angles only. The type of measurements influences the minimum number of observations needed to perform a resection. In case of angle as well as distance measurements a minimum of 2 observations are required, by measuring angles only a minimum of 3 observations should be performed.

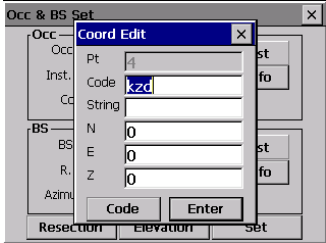
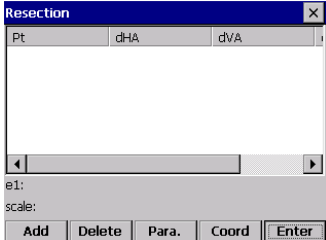
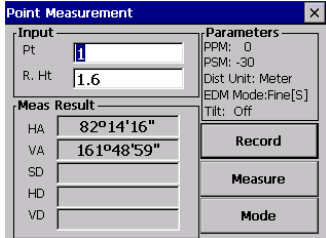
OPERATIONAL STEPS	KEY	DISPLAY
<p>① In [Occ. & BS Set] menu input occupied point name, click [Resection]. If the point name doesn't exist in internal memory, system will prompt to input coordinate after saving the data, click [Resection].</p>	<p>[Resection]</p>	 
<p>② Click [Add] to add a new resection measurement. As shown in the right graph.</p>	<p>[Add]</p>	

SOUTH

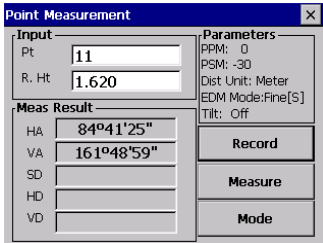
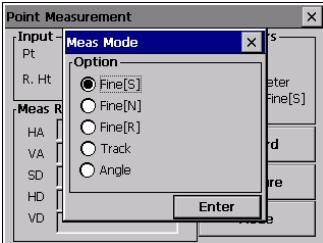
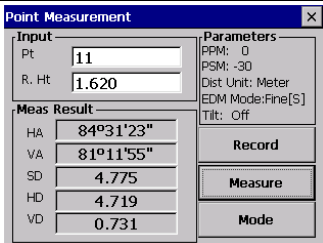
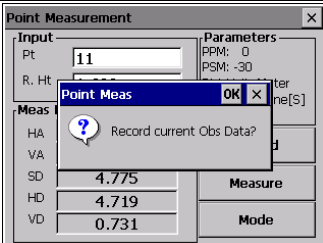
<p>③ Input the number of known point which used for resection and prism height.</p>	<p>Input PT, prism height</p>	
<p>④ Click [Mode] to choose measure mode.</p>	<p>[Mode]</p>	
<p>⑤ Sight the center of target prism; click [Measure] to start measure.</p>	<p>[Measure]</p>	
<p>⑥ After measuring, click [Record], a dialog box shows as the right graph. Click [OK] to record the data to the project.</p>	<p>[Record]</p>	

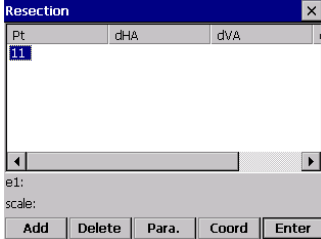
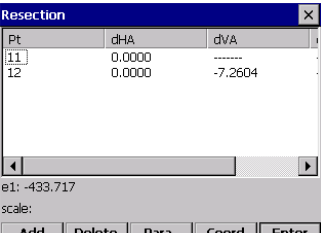
<p>⑦ The system returns to resection main menu. The screen displays the PT just measured. If the coordinate is unknown, system will request user to input the coordinates and then return to resection main menu.</p>		
<p>⑧ Click [Add] again, repeat steps ②~⑥ to finish measuring and recording other resection points. ※1)</p>	<p>[Add]</p>	

SOUTH

⑨ In case 3 angle measurements or 2 angle and distance measurements have been performed, the coordinates of the occupied point can be displayed by pressing [Coord]. Click [Enter]. ※2)

[Coord]

Pt	dHA	dVA
11	0.0000	-----
12		

North 1897.529
East 5344.035
Zenith 893.400

e1: -433.717
scale:

Add Delete Para. Coord Enter

※1) On the lower side of the screen discrepancies (e1) or the standard deviation in N, E, Z direction (sN, sE, sZ) of the occupied point will be displayed. Discrepancies will be shown in case two distance measurements have been performed. They are calculated using the following equations.

$e1 = HD12$ (Calculated using measurements) – $HD12$ (Calculated using known coordinates)

$HD12$ denotes the horizontal distance between the first and second point.

※2) If the distance of more than three points or angles of more than four points have been measured; the standard deviation will be displayed instead of discrepancies. The number of residuals shown depends on the parameters selected. Generally, the worst observation will have the largest residual. This observation can be deleted by placing the bar on this observation using the arrow key and then press [DEL]. The observation is removed from the list. The coordinates of the occupied point, its standard deviation or discrepancies and the residuals of the remaining observations are automatically recomputed.

By clicking [Para.], the parameters which are calculated during resection can be

selected. The following screen will be shown.

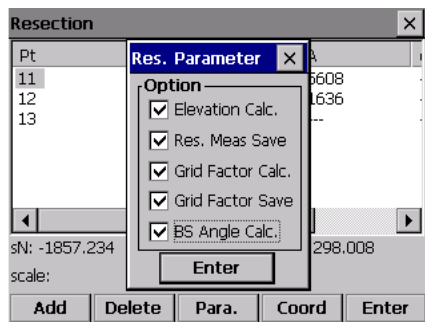

- It is possible to select whether the level of the occupied point, a scale factor or the backsight bearing ('Calculate Bkb') should be calculated. Furthermore it is possible to select whether the calculated scale or the measurements which have been performed ('Store res meas') should be stored.
- After setting, click [Enter] to return to the main resection screen, saving the changed mode and (re)calculation of the occupied point, residuals and the required parameters.

 Press [ENT] in the resection main menu will quit this function and save the coordinates of the occupied point. In case 'Store res meas' was turned on in [PARAM], the measurements which have been performed and which are shown in the box will be saved as well.

 In case 'Calculate Bkb' in [PARAM] was turned on, the backsight bearing will be calculated and set by pressing [ENT] key and leaving the main resection screen.

The calculation will use all measurements which are shown in the box. In order to calculate a backsight bearing of high quality:

The residuals of the horizontal angle should have low values.

The user shouldn't change the horizontal angle when leaving the main resection screen.

NOTE :

1) The measurements can be performed in any order. The point numbers shown in the box in the main resection screen will be sorted by horizontal angle.

2) When 3 points are used for resection using angle measurement only, you must

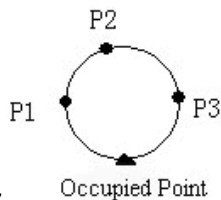

consider the "danger circle."

E.g.:

1) If p1, p2, p3 and OccPt fall on the circle, the result can not be computed.

2) If the point is near the circle then the result is unstable.

3) Residuals are useful to avoid that observations of low quality will be used for the resection calculation. However, in case of a small number of observations or a bad geometrical constellation of the points it is possible that one bad observation influences several residuals.

4) The unit of residuals is similar to the unit of the measurements performed. However the residuals of horizontal angle and vertical angle are always displayed in decimals. E.g.: $3^{\circ}49' 50''$ shows as 3.4950

5) The message 'Occupied point coordinate is not computed' is shown if the calculated scale is not within 0.9~1.1.

6) More than one measurement to the same point can be performed during resection. In that case the character '**' is placed behind the point number. The average of the measurements to same point is used for the calculations.

7) The following table shows which residuals will be shown.

ΔH : The residual of horizontal angle. ΔV : The residual of vertical angle

ΔSD : The residual of slope distance.

NOTE: The residuals which will be shown depend on the measuring mode and whether elevation is calculated.

Calc. Elevation : ON	Calc. Elevation : OFF
Meas Mode : H/V/SD	$\Delta H, \Delta V, \Delta SD$ ΔH
Meas Mode : H/V	$\Delta H, \Delta V$ ΔH

11.1.2 Elevation of Occupied Point

If the elevation of a point to be occupied is not known but a point of known elevation can be observed, then the station elevation can be computed.

Example:

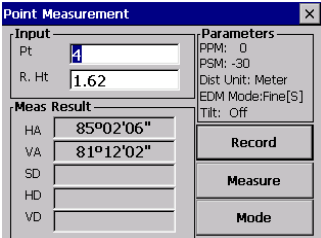
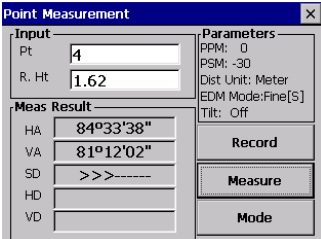
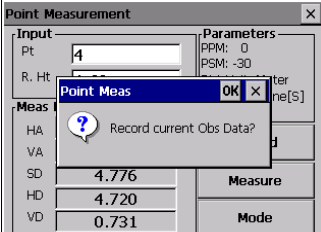
OPERATIONAL STEPS	KEY	DISPLAY
<p>① In [Occ. & BS Set] main menu, click [Elevation]. ※1)</p>	<p>[Elevation]</p>	
<p>② Input known PT and Prism height, and sight the center of prism. Click [Measure] to start survey.</p>	<p>Input PT, Target height [Measure]</p>	
<p>③ Click [Record].</p>	<p>[Record]</p>	

SOUTH

④ Click [OK].

A: If the point name doesn't exist in internal memory, system will prompt to input coordinate As shown in the right graph. System calculates height of occupied point automatically.

[OK]

B: If the coordinate of the point exists in the file, System calculates height of occupied point automatically.

Occ & BS Set

Coord Edit

Pt: 9

Inst. Code: kzd

String:

BS N: 0

BS E: 0

R. Z: 0

Azimu:

Code Enter

Resection Elevation Set

Occ & BS Set

Coord Edit

Pt: 9

Inst. Code: kzd

String:

BS N: 100

BS E: 100

R. Z: 10

Azimu:

Code Enter

Resection Elevation Set

Occ & BS Set

Coord Edit

Pt: 9

Inst. Code: kzd

String:

BS N: 100

BS E: 100

R. Z: 1.881

Azimu:

Code Enter

Resection Elevation Set

Occ & BS Set

Coord Edit

Pt: 4

Inst. Code: kzd

String:

BS N: 3754.763

BS E: -1208.595

R. Z: -0.612

Azimu:

Code Enter

Resection Elevation Set

11.2 BACKSIGHT OBSERVATION (BS OBS)

For record the raw data of backsight point.

Back Sight Observations only can start after setting of occupied point and backsight point.

Example:

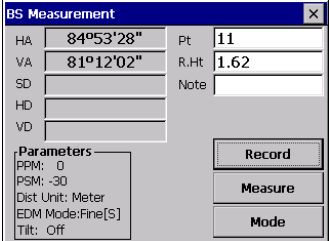
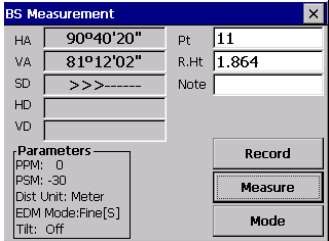
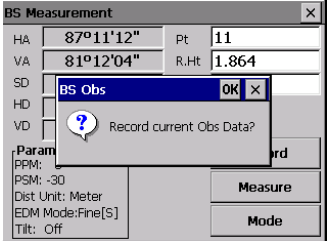
OPERATIONAL STEPS	KEY	DISPLAY
<p>① In [Record] menu click [BSObs] or press [▲]/[▼] to enter into BS measurement</p>	<p>[BSObs]</p>	
<p>② Input PT and R.Ht (Prism height is needed only in elevation measuring). Sight prism center, click [Measure] to start survey.</p>	<p>Input PT, R.Ht.</p>	
<p>③ After measuring click [Record]. A dialog box shows as the right graph.</p>	<p>[Record]</p>	

<p>④ Click [OK] to record data and return to standard survey main menu.</p>	<p>[OK]</p>	
---	-------------	--

[NOTE]: Back Sight Observations only can starts after setting of occupied point and backsight point. Otherwise system will prompt to set occupied point and backsight point and access BS OBS screen.

11.3 FORESIGHT OBSERVATION (FS OBS)

The data of Foresight Observations mainly used for the traverse adjustment calculation.

After setting Occ. point and BS point, the measuring begins.

Example:

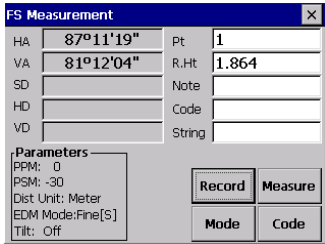
OPERATIONAL STEPS	KEY	DISPLAY
<p>① In [Record] menu click [FSObs] or press [▲]/[▼] to enter into FS measurement.</p>	<p>[FSObs]</p>	

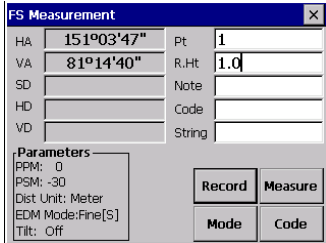
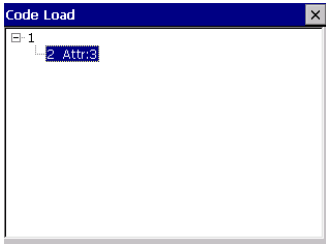
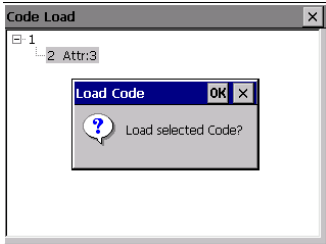
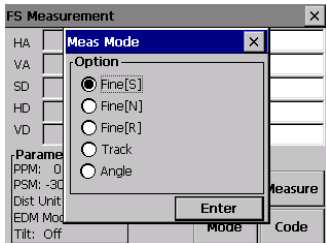
<p>② Input PT, R.Ht .※1), ※ 2)</p>	<p>Input PT, R.Ht</p>	
<p>③ Input code, or click [Code] to call up from code list. System lists stored codes. Click the “+” before the needed code layer. Double click the needed code.</p>		
<p>④ System prompts the dialog box. Click [OK] to select the code and return to measure screen.</p>	<p>[OK]</p>	
<p>⑤ To change measure mode, click [Mode]. Click “○” before the mode, and click [Enter].</p>	<p>[Mode]</p>	

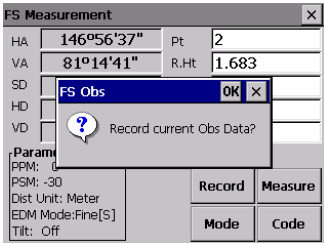
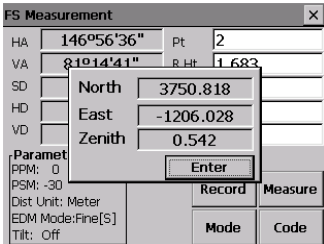
<p>⑥ Click [Measure] to start survey.</p> <p>After measuring, the results display. Click [Record], a dialog box prompts as the right graph.</p>	<p>Measure Record</p>	 <p>The screenshot shows the 'FS Measurement' dialog box with fields for HA (146°56'37"), VA (81°14'41"), Pt (2), and R.Ht (1.683). A 'Record current Obs Data?' dialog box is overlaid with 'OK' and 'X' buttons. The main dialog has 'Record', 'Measure', 'Mode', and 'Code' buttons.</p>
<p>⑦ Click [OK], N、E、Z coordinates display.</p>	<p>[OK]</p>	 <p>The screenshot shows the 'FS Measurement' dialog box with 'North' (3750.818), 'East' (-1206.028), and 'Zenith' (0.542) coordinates displayed. The 'Record' button is highlighted with an 'Enter' key icon. The main dialog has 'Record', 'Measure', 'Mode', and 'Code' buttons.</p>
<p>⑧ Click [Enter], the results are saved, The display returns to standard survey main menu.</p>	<p>[Enter]</p>	

11.4 SIDESHOT OBSERVATION (SS OBS)

OPERATIONAL STEPS	KEY	DISPLAY
<p>① In [Record] menu click [SSObs] or press [▲]/ [▼] to enter SS Measurement.</p>	<p>[SSObs]</p>	
<p>② Input PT, R.Ht. Click [Measure] to start measure.</p>	<p>Input PT, R.Ht [Measure]</p>	
<p>③ After measuring, the results display. Click [Record], a dialog box prompts as the right graph.</p>	<p>[Record]</p>	

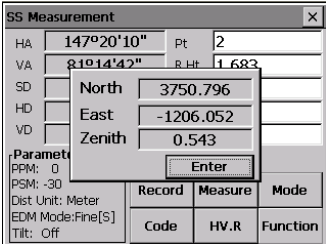
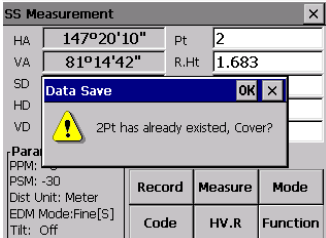
<p>④ Click [OK], N、E、Z coordinates display.</p> <p>If the point exists, system prompts whether to cover the point.</p>	<p>[OK]</p>	 
<p>⑤ Click [Enter], the measurement results are saved.</p> <p>Repeat ②~⑤ to finish measurement.</p>	<p>[Enter]</p>	
<p>※1) Click [Mode], to select measure mode among Fine[S]/Fine [N]/Fine[R]/Track/Angle Meas.</p> <p>※2) Click [Code] to call up code from code list.</p> <p>※3)HV.R: Function used to record raw angle data.</p>		

FUNCTION KEY

In [SSObs], click [Function], the function menu prompts.

SS Measurement			
HA	147°20'09"	Pt	3
VA	81°14'41"	R.Ht	1.683
SD	4.768	Note	
HD	4.712	Code	
VD	0.726	String	
Parameters			
PPM: 0			
PSM: -30			
Dist Unit: Meter			
EDM Mode: Fine[S]			
Tilt: Off			
		Record	Offset Meas
		Code	Plane Offset
			Pt to Line Mode
			Ctrl Input

11.4.1 Offset

Apply the following procedure to a point which can not be measured directly.

Measured data change to raw data directly.

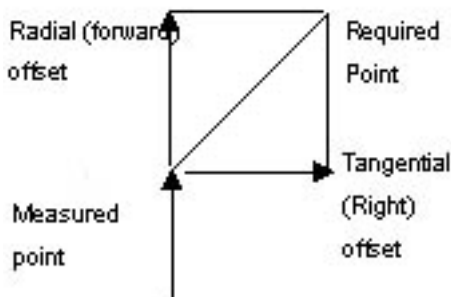

A radial (forward) offset is along the line of sight, with positive away from the instrument, and a tangential (right) offset is perpendicular to the line of sight

with positive to the right, as viewed from the instrument. A vertical offset is positive upwards.

- Offsets may be entered manually if measured by tape, or calculated by measuring a second angle to the required point.

A tangential offset may be calculated by recording a second angle to intersect with the perpendicular offset from the

current observation. This method can be used to obtain an approximate position for the center of an object, for example a tree. Take a shot to the side of the object. When the offset screen has been selected, sight the center of the object, and press [Horizon] to read the horizontal angle. A perpendicular offset from the original line of sight will be calculated and entered to the screen.

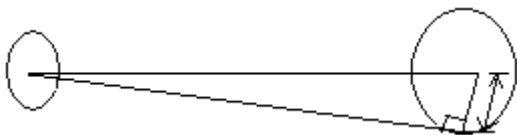

To calculate a vertical offset (remote elevation), make an observation to an accessible point above or below the point required. When in the offset screen, sight the point required, and press [Vertical]. The vertical angle will be used to calculate the difference in elevation from the ground to the point above or below. The offset will be written to the screen. Make the current target height has been entered into the point code screen before selecting [Offset].

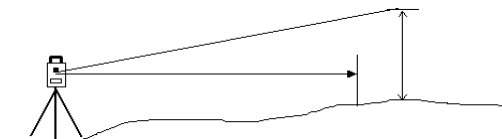

Record an observation as close as possible to the required point.

OPERATIONAL STEPS	KEY	DISPLAY
<p>① In [SS] measurement, sight the prism center.</p> <p>Click [Measure] to start measure.</p>	Measure	
<p>② Keep the instrument still, click [Function].</p> <p>A dialog box prompts as the right graph.</p>	Function	
<p>③ In Function menu, click [Offset] to enter Offset measurement.</p>	[Offset]	

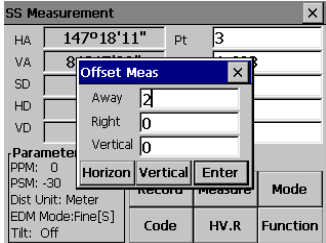
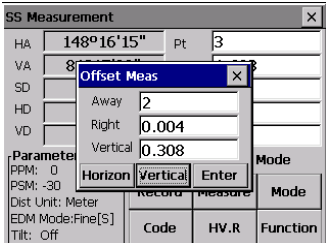
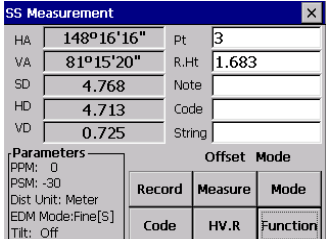
<p>④ Input away offset manually. Away: offset along the line of sight</p>	<p>Input Away offset</p>	 <p>SS Measurement</p> <p>HA 147°18'11" pt 3</p> <p>VA 8</p> <p>SD</p> <p>HD</p> <p>VD</p> <p>Parameter</p> <p>PPM: 0</p> <p>PSM: -30</p> <p>Dist Unit: Meter</p> <p>EDM Mode: Fine[S]</p> <p>Tilt: Off</p> <p>Offset Meas</p> <p>Away 2</p> <p>Right 0</p> <p>Vertical 0</p> <p>Horizon Vertical Enter</p> <p>Record Measure Mode</p> <p>Code HV.R Function</p>
<p>⑤ Collimate offset target point, press [Horizon] or [Vertical], the offset value will be computed and displayed on screen</p> <p>Right: The offset value for right/left direction. (Corresponding [Horizon] key). Vertical: the offset value for vertical direction. (Corresponding [Vertical] key).</p>	<p>[Horizon] or [Vertical]</p>	 <p>SS Measurement</p> <p>HA 148°16'15" pt 3</p> <p>VA 8</p> <p>SD</p> <p>HD</p> <p>VD</p> <p>Parameter</p> <p>PPM: 0</p> <p>PSM: -30</p> <p>Dist Unit: Meter</p> <p>EDM Mode: Fine[S]</p> <p>Tilt: Off</p> <p>Offset Meas</p> <p>Away 2</p> <p>Right 0.004</p> <p>Vertical 0.308</p> <p>Horizon Vertical Enter</p> <p>Record Measure Mode</p> <p>Code HV.R Function</p>
<p>⑥ Click [Enter] to return to SS Measurement screen, the Offset Mode displays.</p>	<p>[Enter]</p>	 <p>SS Measurement</p> <p>HA 148°16'16" pt 3</p> <p>VA 81°15'20" R.Ht 1.683</p> <p>SD 4.768 Note</p> <p>HD 4.713 Code</p> <p>VD 0.725 String</p> <p>Parameters</p> <p>PPM: 0</p> <p>PSM: -30</p> <p>Dist Unit: Meter</p> <p>EDM Mode: Fine[S]</p> <p>Tilt: Off</p> <p>Offset Mode</p> <p>Record Measure Mode</p> <p>Code HV.R Function</p>

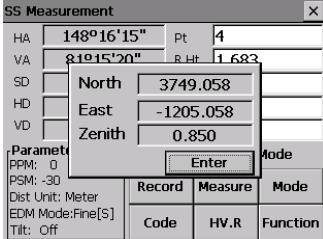
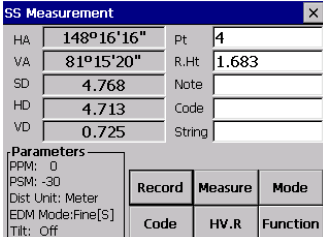
<p>⑦ Click [Record], system calculates coordinates of target point.</p>	<p>[Record]</p>	
<p>⑧ Click [Enter] to return to SS Measurement screen.</p>	<p>[Enter]</p>	

11.4.2 Plane Offset

This mode is similar with **【PROGRAM】** → **【Offset】** → **【Plane Offset】** .

Example:

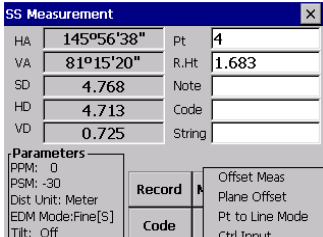
OPERATIONAL STEPS	KEY	DISPLAY
<p>① In SS Measurement, click [Function].</p>	<p>[Function]</p>	

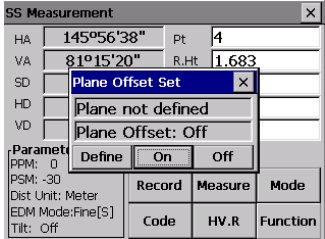
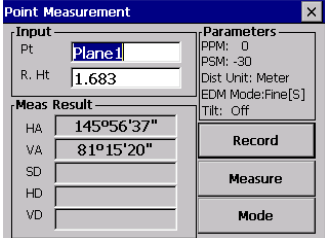
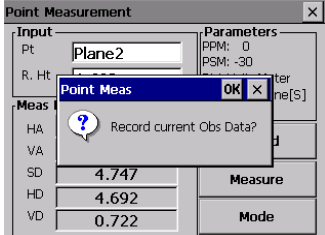
<p>② Click [Plane Offset] to enter into Plane Offset Measure.</p> <p>Click [Define], to enter into Define Plane function. Click [Off] to return to SS Measurement.</p>	<p>[Plane Offset]</p>	
<p>③ Sight the first point of the plane; click [Measure] to start measure.</p>	<p>[Measure]</p>	
<p>④ After measuring click [Record].</p>	<p>[Record]</p>	

SOUTH

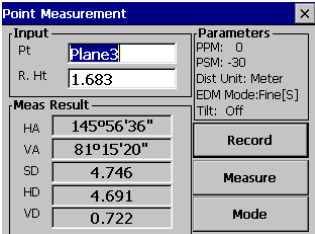
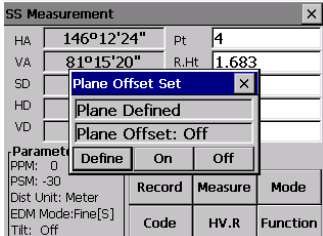
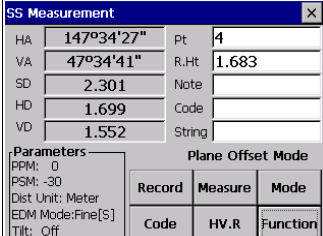
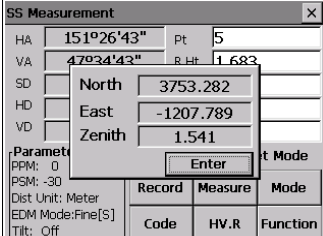
<p>⑤ Repeat steps ③~④ to finish measuring other two points for entering reference plane.</p>		
<p>⑥ After defining the Plane, the system prompts as the right graph. Click [On] to open Plane Offset function. ※1)</p>	<p>[On]</p>	
<p>⑦ Start Plane Offset Measure. Sight the target point on the plane. The distance from this point to the instrument displays.</p>		
<p>⑧ Click [Record] to record results of Plane Offset.</p>	<p>[Record]</p>	

<p>⑨ Click [Enter] to save measuring results.</p> <p>Repeat steps ⑦~⑧ to finish measuring other points on the plane.</p>	[Enter]	<div style="border: 1px solid black; padding: 5px;"> <table border="1" style="width: 100%; border-collapse: collapse; font-size: 0.8em;"> <thead> <tr style="background-color: #000080; color: white;"> <th colspan="4">SS Measurement</th> </tr> </thead> <tbody> <tr> <td>HA</td><td>153°38'52"</td><td>Pt</td><td>7</td> </tr> <tr> <td>VA</td><td>47°34'43"</td><td>R.Ht</td><td>1.683</td> </tr> <tr> <td>SD</td><td>2.276</td><td>Note</td><td></td> </tr> <tr> <td>HD</td><td>1.680</td><td>Code</td><td></td> </tr> <tr> <td>VD</td><td>1.535</td><td>String</td><td></td> </tr> <tr> <td colspan="2">Parameters</td><td colspan="2">Plane Offset Mode</td> </tr> <tr> <td>PPM:</td><td>0</td><td>Record</td><td>Measure</td> </tr> <tr> <td>PSM:</td><td>-30</td><td>Code</td><td>HV.R</td> </tr> <tr> <td>Dist Unit:</td><td>Meter</td><td colspan="2">Function</td> </tr> <tr> <td>EDM Mode:</td><td>Fine[S]</td><td colspan="2"></td> </tr> <tr> <td>Tilt:</td><td>Off</td><td colspan="2"></td> </tr> </tbody> </table> </div>	SS Measurement				HA	153°38'52"	Pt	7	VA	47°34'43"	R.Ht	1.683	SD	2.276	Note		HD	1.680	Code		VD	1.535	String		Parameters		Plane Offset Mode		PPM:	0	Record	Measure	PSM:	-30	Code	HV.R	Dist Unit:	Meter	Function		EDM Mode:	Fine[S]			Tilt:	Off		
SS Measurement																																																		
HA	153°38'52"	Pt	7																																															
VA	47°34'43"	R.Ht	1.683																																															
SD	2.276	Note																																																
HD	1.680	Code																																																
VD	1.535	String																																																
Parameters		Plane Offset Mode																																																
PPM:	0	Record	Measure																																															
PSM:	-30	Code	HV.R																																															
Dist Unit:	Meter	Function																																																
EDM Mode:	Fine[S]																																																	
Tilt:	Off																																																	
<p>※1 [On]: Function key used to display "Plane Offset". In SS Measurement screen "Plane Offset Mode" shows</p> <p style="padding-left: 40px;">[Off]: Function key used to shut "Plane Offset".</p>																																																		

11.4.3 Pt. Line Mode (For Measurement from Point to Line)

This mode is used for coordinate measurement of target points P which treats A (0,0,0) as the origin and line AB as the N axis. See below:

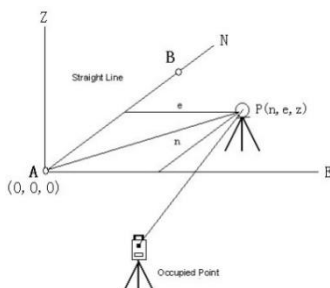

A: reference point 1

B: reference point 2

- After measuring coordinates of point A, B, enter Point & Line Measurement

Mode. Set A, B as reference point 1, 2. Set once again a coordinate system which has A as origin and line AB as N axis. Start measurement again. (Never change information of occupied point during the process.)

Example:

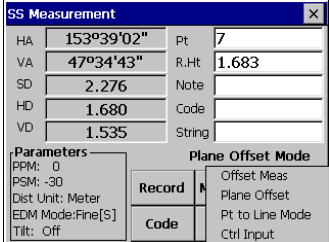
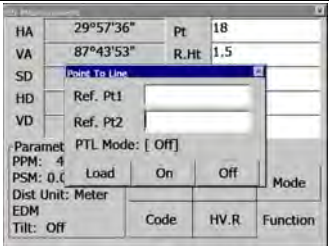
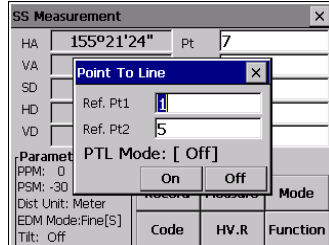
OPERATION STEPS	KEY	DISPLAY
<p>① Measure coordinates of Point A, B, record in the memory. In SS Measurement, click [Pt. Line Mode] to enter into Point Line Mode.</p>	<p>[Pt. Line Mode]</p>	
<p>② Define base line. Enter the Point number of start point and stop point. If the point does not exist, it displays "Coord PT not found!". Press [Enter].</p>		
<p>③ After defining base line click [On] to enter into Pt. Line measure Mode. ※1)</p>	<p>[On]</p>	

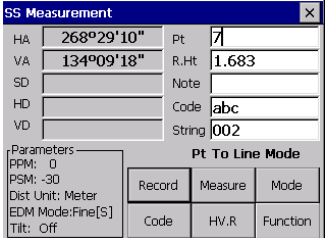
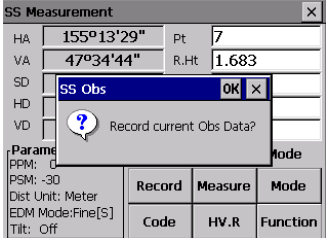
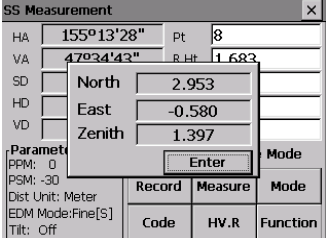
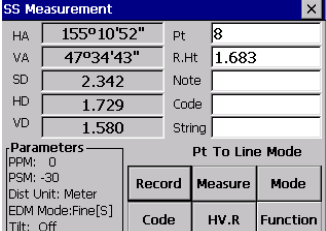
<p>④ Sight prism center, click [Measure] to start measure.</p>	<p>[Measure]</p>	
<p>⑤ After measuring click [Record].</p>	<p>[Record]</p>	
<p>⑥ Click[OK] to display the coordinate.</p>	<p>[OK]</p>	
<p>⑦ Click [Enter] to save the results.. Repeat steps ④~⑥ to finish measuring other points.</p>	<p>[Enter]</p>	

※1)[On]: It is used to activate Point to Line Mode.

[Off]: It is used to disable the Point to Line Mode.

11.4.4 Control Input

Control Input function is used for editing the string and appended code of the point.

OPERATION STEPS	KEY	DISPLAY
<p>① In SS Measurement, Click [CTRL Input] to enter into control code Input function.</p>	<p>[CTRL Input]</p>	
<p>② Input Control code, Code2 and String 2. To call up code in code lib, click [Code].</p>	<p>Input message</p>	
<p>③ Click [Enter], the screen returns to SS Measurement.</p>		

11.5 CROSS SECTION MEASUREMENT

The cross section measurement allows points on a cross section to be measured and downloaded in “chainage, offset and elevation” format.

The operation is similar to the side shot observation. Every cross section must have a center line, to compute the chainage and offsets.

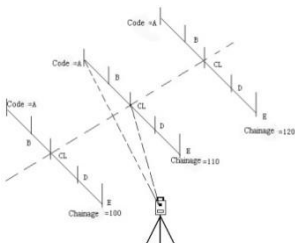



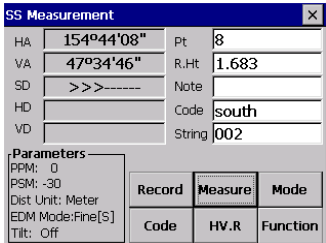
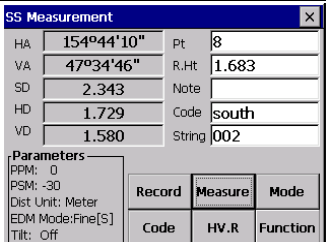
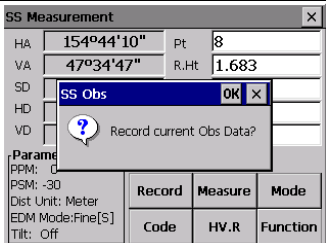

Set occupied point and backsight point.

OPERATIONAL STEPS	KEY	DISPLAY
<p>① In [Record] menu click[X-Sect], a dialog box prompts as the right graph.</p> <p>Input CL Code and String and click [Enter].</p>	<p>[X-Sect]</p> <p>Input CL Code and String</p>	

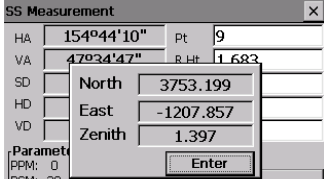
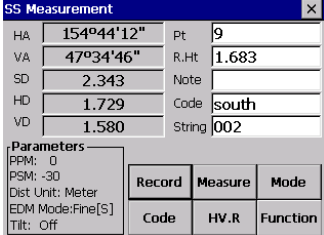
SOUTH

<p>② Start cross section measurement. First measure point on center line. Input code of center line (The code should be same as the code of last screen. The program will identify that it's making center line measurement). Click [Measure] to start survey.</p>	<p>[Measure]</p>	
<p>③ After measuring, display the point result of center-line.</p>		
<p>④ Click [Record] to record measure results.</p>	<p>[Record]</p>	

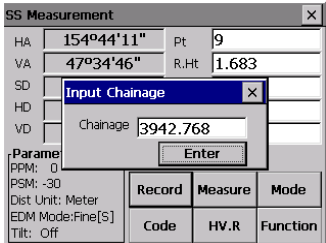
<p>⑤ Click [OK] to display the coordinates of this point. Click [Enter] to save the results.</p>	<p>[OK] [Enter]</p>	
<p>⑥ The screen returns to standard measurement. Input code of each point on the cross section, repeat steps ②~⑤ to finish measuring other points of this chainage and save the result.</p>		

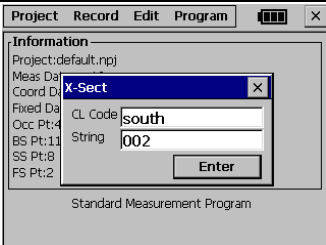
<p>⑦ After collecting all cross section points of this chainage, click  in SS Measurement, and a dialog box prompt as the right graph. Input the chainage of the cross section.(The first chainage number must be input by hand, the following chainages can be calculated.)</p>		
<p>⑧ When the cross section is saved; the screen will display the code of mid-line and string. Click[Enter] to receive the same code or enter new code. Click  to quit X-Sect measurement record.</p>	<p>[Enter]</p>	

<p>⑨ Repeat steps ②~⑧ to finish measuring points of cross section on other chainages.</p>		<div style="border: 1px solid black; padding: 5px;"> <table style="width: 100%; border-collapse: collapse;"> <tr> <th colspan="4" style="background-color: #000080; color: white; padding: 2px;">SS Measurement ✕</th> </tr> <tr> <td style="width: 15%; border: 1px solid gray;">HA</td> <td style="width: 45%; border: 1px solid gray;">155°22'47"</td> <td style="width: 15%; border: 1px solid gray;">Pt</td> <td style="width: 25%; border: 1px solid gray;">15</td> </tr> <tr> <td style="border: 1px solid gray;">VA</td> <td style="border: 1px solid gray;">47°34'47"</td> <td style="border: 1px solid gray;">R.Ht</td> <td style="border: 1px solid gray;">1.683</td> </tr> <tr> <td style="border: 1px solid gray;">SD</td> <td style="border: 1px solid gray;"></td> <td style="border: 1px solid gray;">Note</td> <td style="border: 1px solid gray;"></td> </tr> <tr> <td style="border: 1px solid gray;">HD</td> <td style="border: 1px solid gray;"></td> <td style="border: 1px solid gray;">Code</td> <td style="border: 1px solid gray;">south</td> </tr> <tr> <td style="border: 1px solid gray;">VD</td> <td style="border: 1px solid gray;"></td> <td style="border: 1px solid gray;">String</td> <td style="border: 1px solid gray;">002</td> </tr> <tr> <td colspan="4" style="padding: 5px;"> Parameters PPM: 0 PSM: -30 Dist Unit: Meter EDM Mode: Fine[S] Tilt: Off </td> </tr> <tr> <td colspan="2"></td> <td style="border: 1px solid gray; text-align: center;">Record</td> <td style="border: 1px solid gray; text-align: center;">Measure</td> </tr> <tr> <td colspan="2"></td> <td style="border: 1px solid gray; text-align: center;">Code</td> <td style="border: 1px solid gray; text-align: center;">Mode</td> </tr> <tr> <td colspan="2"></td> <td style="border: 1px solid gray; text-align: center;">HV.R</td> <td style="border: 1px solid gray; text-align: center;">Function</td> </tr> </table> </div>	SS Measurement ✕				HA	155°22'47"	Pt	15	VA	47°34'47"	R.Ht	1.683	SD		Note		HD		Code	south	VD		String	002	Parameters PPM: 0 PSM: -30 Dist Unit: Meter EDM Mode: Fine[S] Tilt: Off						Record	Measure			Code	Mode			HV.R	Function
SS Measurement ✕																																										
HA	155°22'47"	Pt	15																																							
VA	47°34'47"	R.Ht	1.683																																							
SD		Note																																								
HD		Code	south																																							
VD		String	002																																							
Parameters PPM: 0 PSM: -30 Dist Unit: Meter EDM Mode: Fine[S] Tilt: Off																																										
		Record	Measure																																							
		Code	Mode																																							
		HV.R	Function																																							

[NOTE]:

- (1.) The maximum point number for each cross section is 60.
- (2.) The chainage number automatically displayed is calculated from the horizontal distance from its occupied point to its center.

12. EDIT DATA

The edit menu provides options to edit raw data, point coordinates, the fixed point data library, and the code library.

Project	Record	Edit	Program	☐☐☐	✕
Information					
Project: default.npj					
Meas Data: 16					
Coord Data: 11					
Fixed Data: 2					
Occ Pt: 4					
BS Pt: 11					
SS Pt: 8					
FS Pt: 2					
Standard Measurement Program					

Raw Data
 Coord Data
 Fixed Data
 Code Data
 Fill-Cut Data

12.1 EDIT RAW DATA

To edit the raw data from the current job select **Raw Data** from the **Edit** menu.:

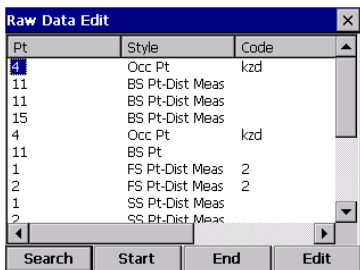

Function keys at the bottom of the screen:

[Start]: Go to the beginning of this file.

[End]: Return to the end of the file

[Search]: To search a specific point, code or string in the file

Example

OPERATION STEPS	KEY	DISPLAY
<p>① In Edit menu, click [Raw Data], the system lists all measurement data of the project.</p>	<p>[Raw Data]</p>	

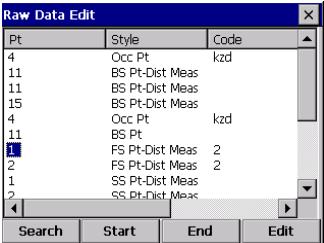
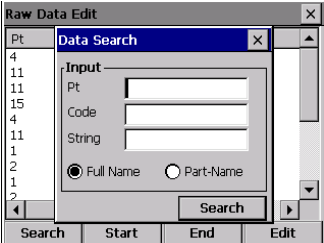
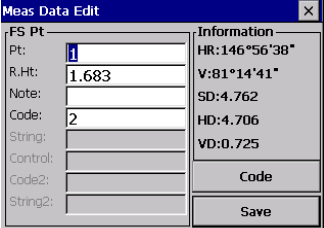
<p>② Find the needed data.</p> <p>A: Click the slide bar to view all data. Click the needed point name when it appears. You can press [▲]/[▼] to display the data.</p> <p>B: Click [Search], in the prompt dialog box input PT, Code, String, and select between Full Name and Part Name. Click [Search] to start search.</p>		<p>A:</p>  <p>B:</p> 
<p>③ After finding the needed data, click [Edit], the Meas. Data Edit dialog box appears.</p>	<p>[Edit]</p>	

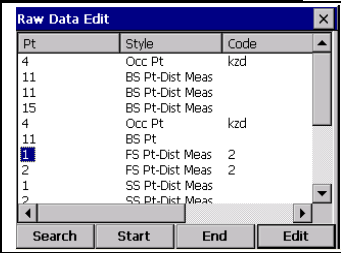
<p>④ Input new data, and then click [Save], system returns to last screen. ※1), ※2)</p>	[Save]	
<p>※1) Date, time and measurement data can't be modified. ※2) Press [ESC] to return to standard survey main menu.</p>		

NOTE:

1. The range of each coordinate is from -9999999.999 to 9999999.999
2. Coordinates that are entered or changed are rounded to 3 decimal places.

12.2 EDIT COORDINATE DATA

The coordinates generated from the current job may be edited or point coordinates may be manually entered. In [Edit] menu click [Coord. Data].

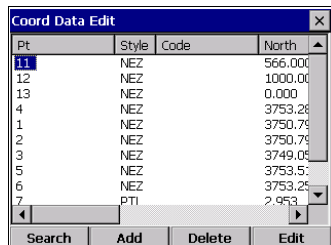

Pt	Style	Code	North
11	NEZ		566.000
12	NEZ		1000.000
13	NEZ		0.000
4	NEZ		3753.28
1	NEZ		3750.75
2	NEZ		3750.75
3	NEZ		3749.05
5	NEZ		3753.55
6	NEZ		3753.25
7	PTI		2.953

12.2.1 Edit Coord. Data

Example:

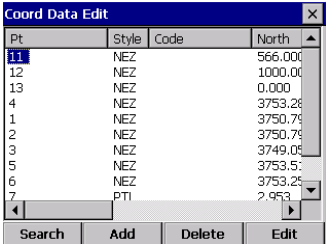
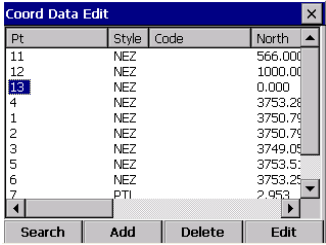
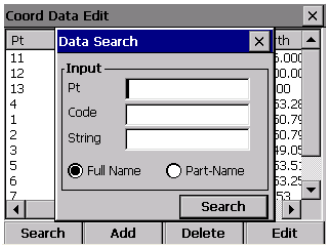
OPERATIONAL STEPS	KEY	DISPLAY																																												
<p>① In Edit Menu, click [Coord. Data], system lists all coord. data in the project.</p>	<p>[Coord. Data]</p>	 <table border="1"> <thead> <tr> <th>Pt</th> <th>Style</th> <th>Code</th> <th>North</th> </tr> </thead> <tbody> <tr><td>11</td><td>NEZ</td><td></td><td>566.000</td></tr> <tr><td>12</td><td>NEZ</td><td></td><td>1000.00</td></tr> <tr><td>13</td><td>NEZ</td><td></td><td>0.000</td></tr> <tr><td>4</td><td>NEZ</td><td></td><td>3753.26</td></tr> <tr><td>1</td><td>NEZ</td><td></td><td>3750.79</td></tr> <tr><td>2</td><td>NEZ</td><td></td><td>3750.79</td></tr> <tr><td>3</td><td>NEZ</td><td></td><td>3749.05</td></tr> <tr><td>5</td><td>NEZ</td><td></td><td>3753.5</td></tr> <tr><td>6</td><td>NEZ</td><td></td><td>3753.25</td></tr> <tr><td>7</td><td>PTI</td><td></td><td>2.953</td></tr> </tbody> </table>	Pt	Style	Code	North	11	NEZ		566.000	12	NEZ		1000.00	13	NEZ		0.000	4	NEZ		3753.26	1	NEZ		3750.79	2	NEZ		3750.79	3	NEZ		3749.05	5	NEZ		3753.5	6	NEZ		3753.25	7	PTI		2.953
Pt	Style	Code	North																																											
11	NEZ		566.000																																											
12	NEZ		1000.00																																											
13	NEZ		0.000																																											
4	NEZ		3753.26																																											
1	NEZ		3750.79																																											
2	NEZ		3750.79																																											
3	NEZ		3749.05																																											
5	NEZ		3753.5																																											
6	NEZ		3753.25																																											
7	PTI		2.953																																											
<p>② Search the needed coord. data</p> <p>A: Click the slide bar to display all coord.data. Click the needed point name when it appears. You can press [▲]/[▼] to view the data.</p> <p>B: Click [Search], in the prompt dialog box input PT, Code, String, and select between Full Name and Part Name. Click [Search] to start search.</p>		<p>A:</p>  <p>B:</p> 																																												

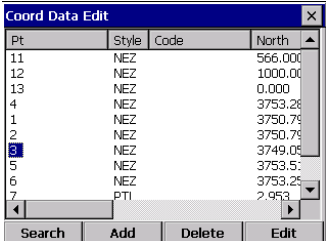
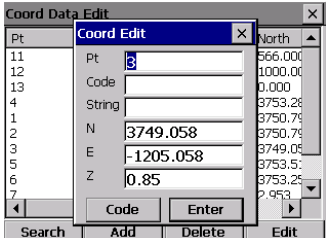
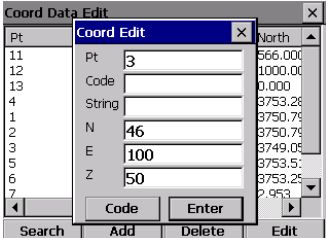
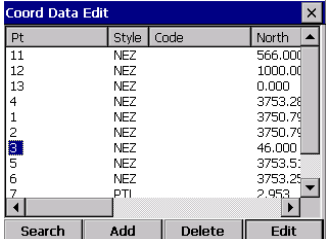
<p>③ After finding the needed data, click [Edit], the Coord. Data Edit dialog box appears.</p>		
<p>④ Click [Edit], the dialog box of this point coordinates prompts.</p>	<p>[Edit]</p>	
<p>⑤ Input new data</p>	<p>Input data</p>	
<p>⑥ Click [Enter], the screen returns to the Coord. Data Edit dialog box, the data is rectified.</p>	<p>[Enter]</p>	

12.2.2 Add Coord. Data

Example:

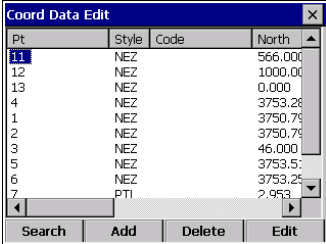
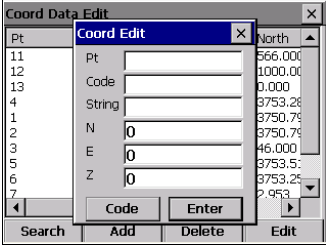
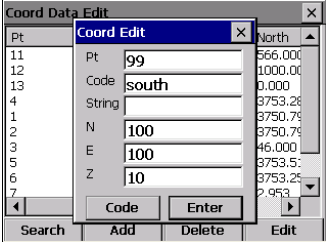
OPERATIONAL STEPS	KEY	DISPLAY
<p>① In Edit menu, click [Coord. Data], the system lists all coordinate data in the job.</p>	<p>[Coord. Data]</p>	
<p>② Click [Add], Coord Edit dialogue will display, as shown on the right.</p>	<p>[Add]</p>	
<p>③ Input PT ID, Code, String, and N, E, Z coordinate.</p>	<p>Input PT ID, Code, String, and coordinat</p>	

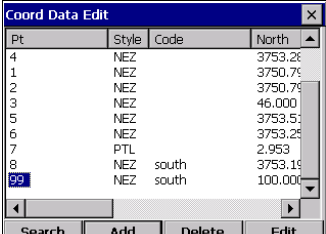
<p>④ Click [Enter], and return to previous screen. The data will be added on the bottom of the profiles.</p>	<p>[Enter]</p>	 <table border="1" style="width: 100%; border-collapse: collapse;"> <thead> <tr> <th>Pt</th> <th>Style</th> <th>Code</th> <th>North</th> </tr> </thead> <tbody> <tr><td>4</td><td>NEZ</td><td></td><td>3753.26</td></tr> <tr><td>1</td><td>NEZ</td><td></td><td>3750.75</td></tr> <tr><td>2</td><td>NEZ</td><td></td><td>3750.75</td></tr> <tr><td>3</td><td>NEZ</td><td></td><td>46.000</td></tr> <tr><td>5</td><td>NEZ</td><td></td><td>3753.51</td></tr> <tr><td>6</td><td>NEZ</td><td></td><td>3753.25</td></tr> <tr><td>7</td><td>PTL</td><td></td><td>2.953</td></tr> <tr><td>8</td><td>NEZ</td><td>south</td><td>3753.19</td></tr> <tr style="background-color: #e0f0ff;"><td>99</td><td>NEZ</td><td>south</td><td>100.000</td></tr> </tbody> </table>	Pt	Style	Code	North	4	NEZ		3753.26	1	NEZ		3750.75	2	NEZ		3750.75	3	NEZ		46.000	5	NEZ		3753.51	6	NEZ		3753.25	7	PTL		2.953	8	NEZ	south	3753.19	99	NEZ	south	100.000
Pt	Style	Code	North																																							
4	NEZ		3753.26																																							
1	NEZ		3750.75																																							
2	NEZ		3750.75																																							
3	NEZ		46.000																																							
5	NEZ		3753.51																																							
6	NEZ		3753.25																																							
7	PTL		2.953																																							
8	NEZ	south	3753.19																																							
99	NEZ	south	100.000																																							

12.2.3 Delete Coord. Data

Example:

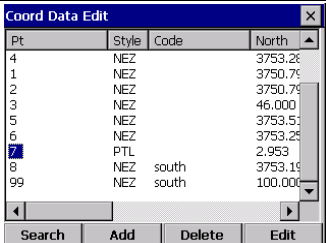
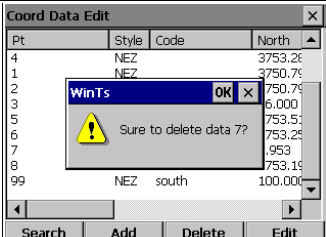
OPERATIONAL STEPS	KEY	DISPLAY																																								
<p>① Find the data to be deleted with the method mentioned previously.</p>		 <table border="1" style="width: 100%; border-collapse: collapse;"> <thead> <tr> <th>Pt</th> <th>Style</th> <th>Code</th> <th>North</th> </tr> </thead> <tbody> <tr><td>4</td><td>NEZ</td><td></td><td>3753.26</td></tr> <tr><td>1</td><td>NEZ</td><td></td><td>3750.75</td></tr> <tr><td>2</td><td>NEZ</td><td></td><td>3750.75</td></tr> <tr><td>3</td><td>NEZ</td><td></td><td>46.000</td></tr> <tr><td>5</td><td>NEZ</td><td></td><td>3753.51</td></tr> <tr><td>6</td><td>NEZ</td><td></td><td>3753.25</td></tr> <tr style="background-color: #e0f0ff;"><td>7</td><td>PTL</td><td></td><td>2.953</td></tr> <tr><td>8</td><td>NEZ</td><td>south</td><td>3753.19</td></tr> <tr><td>99</td><td>NEZ</td><td>south</td><td>100.000</td></tr> </tbody> </table>	Pt	Style	Code	North	4	NEZ		3753.26	1	NEZ		3750.75	2	NEZ		3750.75	3	NEZ		46.000	5	NEZ		3753.51	6	NEZ		3753.25	7	PTL		2.953	8	NEZ	south	3753.19	99	NEZ	south	100.000
Pt	Style	Code	North																																							
4	NEZ		3753.26																																							
1	NEZ		3750.75																																							
2	NEZ		3750.75																																							
3	NEZ		46.000																																							
5	NEZ		3753.51																																							
6	NEZ		3753.25																																							
7	PTL		2.953																																							
8	NEZ	south	3753.19																																							
99	NEZ	south	100.000																																							
<p>② Click [Del], a notice is displayed, as shown on the right.</p>	<p>[Del]</p>	 <table border="1" style="width: 100%; border-collapse: collapse;"> <thead> <tr> <th>Pt</th> <th>Style</th> <th>Code</th> <th>North</th> </tr> </thead> <tbody> <tr><td>4</td><td>NEZ</td><td></td><td>3753.26</td></tr> <tr><td>1</td><td>NEZ</td><td></td><td>3750.75</td></tr> <tr><td>2</td><td>NEZ</td><td></td><td>3750.75</td></tr> <tr><td>3</td><td>NEZ</td><td></td><td>46.000</td></tr> <tr><td>5</td><td>NEZ</td><td></td><td>3753.51</td></tr> <tr><td>6</td><td>NEZ</td><td></td><td>753.25</td></tr> <tr style="background-color: #e0f0ff;"><td>7</td><td></td><td></td><td>,953</td></tr> <tr><td>8</td><td></td><td></td><td>753.19</td></tr> <tr><td>99</td><td>NEZ</td><td>south</td><td>100.000</td></tr> </tbody> </table>	Pt	Style	Code	North	4	NEZ		3753.26	1	NEZ		3750.75	2	NEZ		3750.75	3	NEZ		46.000	5	NEZ		3753.51	6	NEZ		753.25	7			,953	8			753.19	99	NEZ	south	100.000
Pt	Style	Code	North																																							
4	NEZ		3753.26																																							
1	NEZ		3750.75																																							
2	NEZ		3750.75																																							
3	NEZ		46.000																																							
5	NEZ		3753.51																																							
6	NEZ		753.25																																							
7			,953																																							
8			753.19																																							
99	NEZ	south	100.000																																							

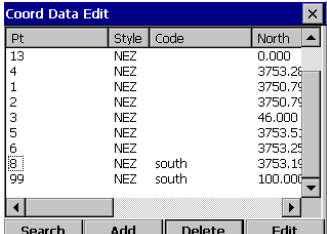
<p>③ Click [OK] and the data are deleted. The screen returns, and the cursor moves to next row.</p>	<p>[OK]</p>	 <table border="1"> <thead> <tr> <th>Pt</th> <th>Style</th> <th>Code</th> <th>North</th> </tr> </thead> <tbody> <tr><td>13</td><td>NEZ</td><td></td><td>0.000</td></tr> <tr><td>4</td><td>NEZ</td><td></td><td>3753.26</td></tr> <tr><td>1</td><td>NEZ</td><td></td><td>3750.79</td></tr> <tr><td>2</td><td>NEZ</td><td></td><td>3750.79</td></tr> <tr><td>3</td><td>NEZ</td><td></td><td>46.000</td></tr> <tr><td>5</td><td>NEZ</td><td></td><td>3753.51</td></tr> <tr><td>6</td><td>NEZ</td><td></td><td>3753.25</td></tr> <tr><td>8</td><td>NEZ</td><td>south</td><td>3753.19</td></tr> <tr><td>99</td><td>NEZ</td><td>south</td><td>100.000</td></tr> </tbody> </table>	Pt	Style	Code	North	13	NEZ		0.000	4	NEZ		3753.26	1	NEZ		3750.79	2	NEZ		3750.79	3	NEZ		46.000	5	NEZ		3753.51	6	NEZ		3753.25	8	NEZ	south	3753.19	99	NEZ	south	100.000
Pt	Style	Code	North																																							
13	NEZ		0.000																																							
4	NEZ		3753.26																																							
1	NEZ		3750.79																																							
2	NEZ		3750.79																																							
3	NEZ		46.000																																							
5	NEZ		3753.51																																							
6	NEZ		3753.25																																							
8	NEZ	south	3753.19																																							
99	NEZ	south	100.000																																							

- NOTE:**
1. The range of each coordinate is from -9999999.999 to 9999999.999
 2. Coordinates that are entered or changed are rounded to 3 decimal places.

12.3 EDIT FIXED POINT DATA

To edit the fixed point library select Fixed Data from the EDIT menu. This function is used to edit the coordinates of control point. Editing the fixed point data is similar to editing Coord.Data in the EDIT menu.

12.4 CODE DATA

To edit the code library select Code Lib from the EDIT menu.

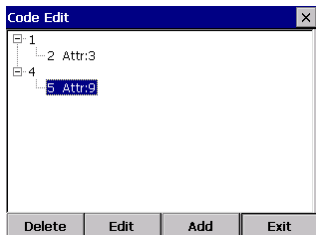

[Delete]: Delete a layer.[Edit]: Rename a layer.[Add]: Add a layer.

12.4.1 Create New Layer

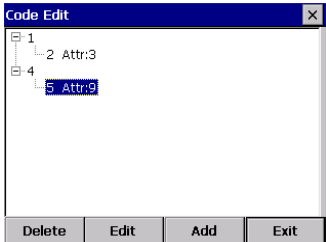
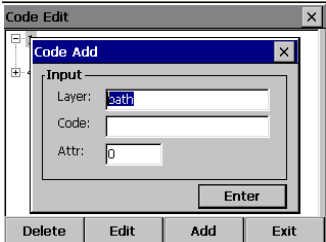
OPERATIONAL STEPS	KEY	DISPLAY
<p>① In Edit Menu, click [Code Data], the system lists all code data in the job.</p>	<p>[Code Data]</p>	 <p>The screenshot shows a 'Code Edit' window with a tree view. The tree has a root node '1' with a child '2 Attr:3', which has a child '4', which in turn has a child '5 Attr:9'. Node '5' is selected and highlighted in blue. At the bottom of the window are four buttons: 'Delete', 'Edit', 'Add', and 'Exit'.</p>
<p>② Click [Add] to display a dialogue as shown on the right. Input Layer, Code and Attribute in the dialogue.</p>	<p>[Add]</p>	 <p>The screenshot shows a 'Code Add' dialog box within the 'Code Edit' window. It has an 'Input' section with three fields: 'Layer:' containing '33th', 'Code:' which is empty, and 'Attr:' containing '0'. There is an 'Enter' button at the bottom right of the input section. The 'Code Edit' window's 'Delete', 'Edit', 'Add', and 'Exit' buttons are visible at the bottom.</p>

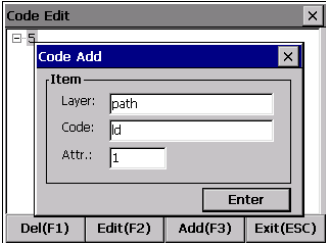
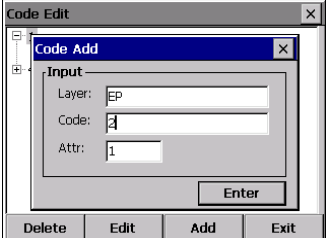
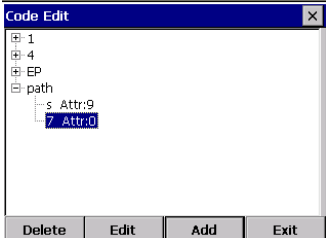
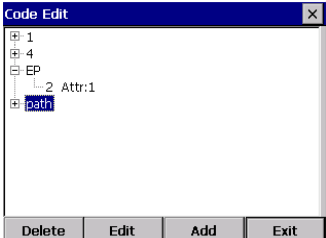
<p>③</p> <p>A: To input new code on an existed layer, just input the code and attribute.</p> <p>B: To add a layer, input the new layer, code, and attribute.</p>		 
<p>④</p> <p>A: New codes are added under the layer.</p> <p>B: A new code layer and code will be created.</p>		 

12.4.2 Edit Code Layer/Code

OPERATIONAL STEPS	KEY	DISPLAY
<p>① Use the stylus to click on the layer or code to be edited.</p>		<p>The display shows two sequential screenshots of the 'Code Edit' dialog box. In the first, a tree view on the left shows '1' selected. In the second, '2 Attr:3' is selected. Both screenshots show a list of items: '1', '2 Attr:3', '4', 'EP', and 'path'. At the bottom of each dialog are buttons for 'Delete', 'Edit', 'Add', and 'Exit'.</p>
<p>② Click [Edit]. Input new data.</p>	<p>[Edit]</p>	<p>The display shows two sequential screenshots of the 'Edit' dialog box. The top screenshot shows the 'Layer' field with '1' entered. The bottom screenshot shows the 'Code' field with '2' and the 'Attr' field with '3' entered. Both screenshots show an 'Input' section with an 'OK' button at the bottom. At the bottom of the overall dialog are buttons for 'Delete', 'Edit', 'Add', and 'Exit'.</p>

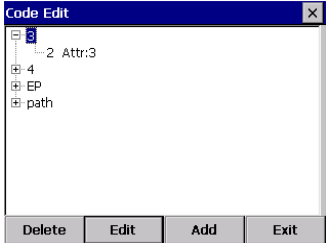
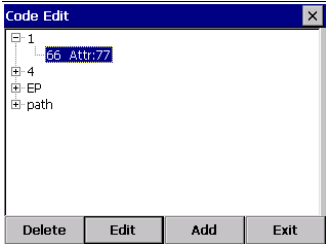
<p>③ After editing, click [Enter].</p>	<p>[Enter]</p>	<p>A: Layer</p>  <p>B: Code</p> 
--	----------------	--

12.4.3 Delete Code

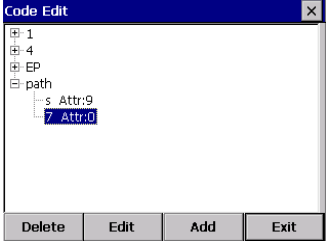
OPERATIONAL STEPS	KEY	DISPLAY
<p>① Use the stylus to click the code to be deleted.</p>		

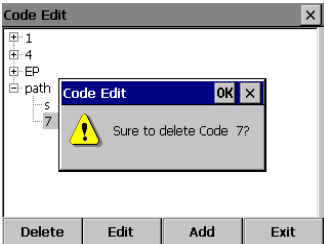
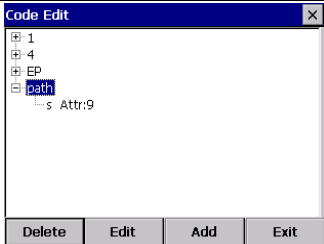
<p>② Click [Delete], a notice appears as shown on the right.</p>	<p>[Delete]</p>	
<p>③ Click [OK], the screen returns, and the code is deleted.※1)</p>	<p>[OK]</p>	
<p>※1) The layer can't be deleted when the layer contains codes.</p>		

12.5 FILL/ CUT DATA

The fill-cut data generated by the layout option can be viewed by the [EDIT]→[Fill-Cut Data] option. The display shows the coordinates saved during setout, and the difference to the uploaded coordinate. As shown in the graph below:

Pt	Code	North
99	south	100.000
100		100.000

Search Next Start End

- This function can realize search for the fill-cut data.
- Fill-cut data can not be edited.

13. PROGRAM MENU

The menu includes below functions:

- (1) Set Out
- (2) Roads
- (3)Cogo
- (4) Traverse
- (5)B.Boards
- (6) Tape Dim

13.1 SET OUT

To show the SET OUT menu, from the **【Program】** menu, select **【Set Out】** . The setting out option allows setting out by point number, strings, alignments and cross sections.

- The basic routine for setting out is similar in all these methods, except for the way data is uploaded and the setup sequence.
- Setting out points allows setting out by point number in point number order. Setting out strings allows setting out by string or point code in the order in which the points were uploaded within the string. Setting out of alignment and cross sections, points are specified by chainage and offset with reference to an uploaded alignment.

13.1.1 Occupied Point&Backsight Point

In [Program] menu, click [Set Out]→[Setup], in the prompt menu click [Set] to enter into Occ.&BS Set dialog box. The setting procedure is similar to those in [RECORD] menu.

- If alignment data exists, the occupied point screen changes to include chainage and offset:

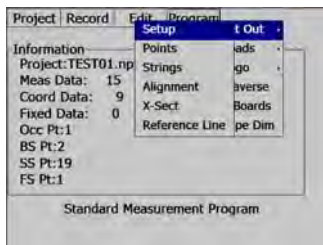

- Here the method of using alignment to set occupied point and backsight point will be introduced.

Example:

OPERATION STEPS	KEY	DISPLAY
<p>① In [Program] menu, click [Setout], in the prompt box click [Setup] to enter into Occ. &BS Set screen.</p>	<p>[Set Out] [Setup]</p>	
<p>② If alignment data exists in internal memory, you can click [Align] to set the occupied point. Here the method of using alignment to</p>	<p>[Align.]</p>	

SOUTH

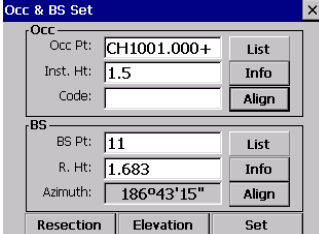
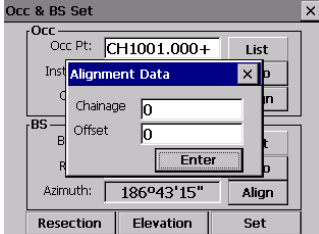
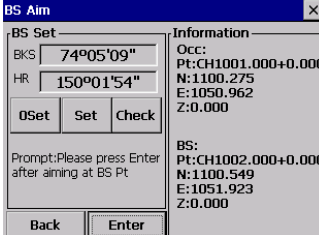
<p>setup occupied point and azimuth angle is introduced. In "Occ" field click [Align.] to start using chainage to setup station function.</p>		
<p>③ Input Chainage and Offset, and click [Enter].</p>	<p>Input station information [Enter]</p>	
<p>④ Input instrument height and code, then click "Align." in "BS" field. In the box input Chainage and Offset and then click [Enter].</p>		
<p>⑤ System calculates azimuth, click [Set]. In the display shown as right the Backsight azimuth is set.</p>	<p>[Set]</p>	

<p>⑥ The occupied point and backsight azimuth is saved, and then the alignment setout data screen displays.</p>		
---	--	--

- If you already have entered the occupied point and backsight point details from either RECORD or SETOUT menus, you can skip these routines and go directly to the set out POINTS,STRINGS,ALIGN or X-SECTS.

13.1.2 Point Set Out

After setting occupied point and backsight point, you can start point setting out

Example:

OPERATIONAL STEPS	KEY	DISPLAY
<p>① In [Program] menu, click [Set Out], in the prompt box click [Points].</p>	<p>[Set Out] [Point]</p>	

② In the prompt dialog box input the PT and Prism Height.

A:

If the coordinates of the point number exists in memory, system will call up the point automatically.

B:

If the coordinate data of the point is not stored in memory, system will recommends that to input setout point.

C:

The point to be set out can be presaved in the project, then click [List] to call up.

A:

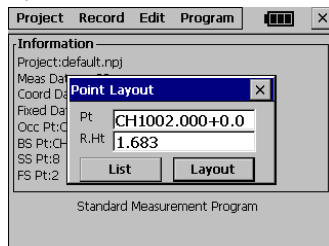

B:

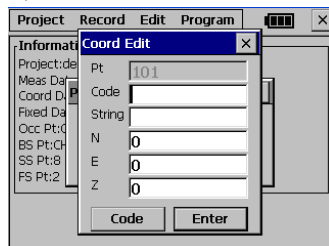



C:

Pt	Code	North
11		566.000
12		1000.000
13		0.000
4		3753.282
1		3750.796
2		3750.796
3		46.000
5		3753.514
6		3753.258
8	south	3753.199

Search Start End Load

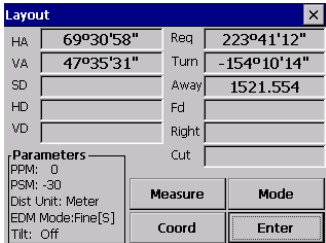
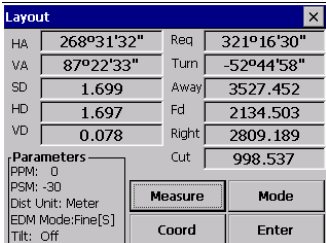
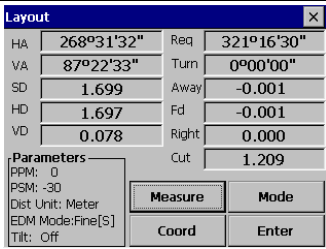
SOUTH

<p>③ After setting the set out point, click [Set Out] to start setting out. Sight the prism center; click [Measure] to start measure. ※1)</p>	<p>[Set Out] [Measure]</p>	
<p>④ Rotate the telescope, making "Turn" item and "→" item display as 0, and ask the rodman to move the prism.</p>		
<p>⑤ Sight the prism center, and click [Measure] to start measure. Ask the rod man to move prism frontward and backward. Making "Away" item and "↑" item displays as 0.</p>	<p>Measure</p>	

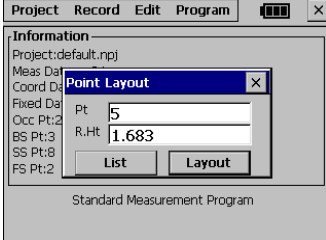
<p>⑥ When the four items are displaying 0, the point to be set out is found. "Cut" item shows the value of dig and fill. When it is positive, it means to dig. When it is minus, it means to fill.</p>		
<p>⑦ After setting out, click [Enter] to quit the screen displays as the graph. Repeat steps ②~⑥ to finish setting out other point.</p>	<p>[Enter]</p>	
<p>⑧ In PT Layout screen click "X" to return to Standard Survey main menu.</p>		
<p>※1) Click [Mode] to choose mode among Fine[s]/Fine [N]/Fine[r]/Track.</p>		

Explanation: _____

Layout			
HA	123°39'31"	Req	208°27'45"
VA	105°51'00"	Turn	-84°48'14"
SD	0.125	Away	-0.004
HD	0.120	Fd	-0.110
VD	-0.034	Right	0.116
		Cut	-0.001

Parameters	
PPM:	0
PSM:	-30
Dist. Unit:	Meter
EDM Mode:	Fine[R]
TR:	2AXIS

Measura	Mode
Coord	Enter

Req: The angle required from occupied point to set-out point.

Turn: The angle that should rotated. When it is 0, means the bearing angle is correct.

Away: The distance required from prism to set-out point. Positive sign indicates that prism should move far from instrument. Negative sign indicates that prism should move towards instrument. The value means the distance to be moved.

Fd ↑ : The distance along the line of sight to the instrument and is positive away from the instrument. Positive sign means the point is in front of sight line; Positive sign means the point is behind sightline.

Right → : It is perpendicular to the line of sight with positive to the right when facing the instrument. Positive sign means the point is in the right side of sight line; Positive sign means the point is in the left side of sightline.

Cut: The elevate difference to the point. Positive sign indicates that this point is higher than calculated value and it should be cut. Negative sign indicates that it should be filled. The value is the fill-cut data value.

- Anytime you click "X" on the upper right screen to return to Pt No screen, you can input a new point and set out next point. Or click [List] to call up data stored in internal memory. If the point is new, system will recommends you to input its coordinate.

13.1.3String Setout

After setting occupied point and backsight point, you can start string setting out

Example:

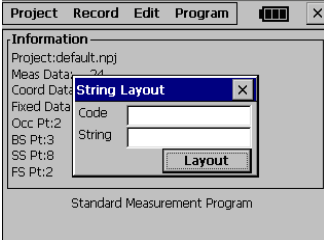
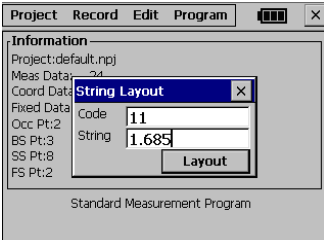
OPERATIONAL STEPS	KEY	DISPLAY
<p>① In [Program] menu, click [Set Out], in the prompt menu click [Strings]</p>	<p>[Set Out] [Strings]</p>	
	<p>[Set Out]</p>	

<p>③ Sight the prism center and click [Measure] to start measure. The setting out method is same as point setting out.</p>	<p>[Measure]</p>	
<p>④ After setting out click [Enter] to quit. The system displays the second point of the string. Click [Set Out] to start setting out.</p>	<p>[Enter]</p>	

[Note]: A fixed point data file can not be used in String Setout.

13.1.4 Reference line

This program facilitates stake-out or checking lines for buildings, sections of road, simple excavations, etc.

What Reference Line is:

A reference line can be defined as a known base line. The

reference line can be offset longitudinally, in parallel or vertically to the base line, or be rotated around the first base point as required.

Definition of Base Line:

The base line is fixed by 2 base points that can be defined in 3 ways:

- Measured points
- Enter coordinates using keypad
- Select point from memory

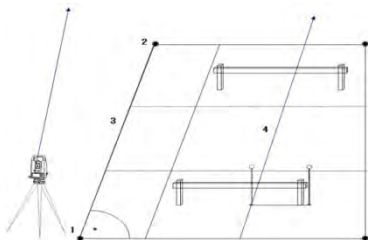

In the picture:

1. 1st base point
2. 2nd base point
3. Baseline
4. Reference line

In the process of using base line, the base line can be offset longitudinally, parallel and vertically or rotated. This new line is called the reference line. All measured data refers to the reference line.

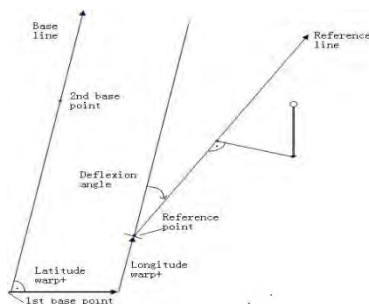

Offset: Parallel offset of the reference line to the right, referred to the direction of the base line.

Line: Longitudinal offset of the start point (=reference point) of the reference line in the direction of base point.

HZ: Height offset; the reference line is higher than the selected reference height.

Rotate: Rotation of the reference line clockwise around the reference point.

The meaning of soft keys under the screen of Ref.Line Define:

[F1]([NewBL]): Return to Ref.Line Define screen to re-define base line.

[F2]([MEAS]): The offset value of point to be measured related to the reference line.

[F3]([STAKE]): Activate the Orthogonal Stake Out.

[F4]([OSET]): Set all offset values/rotate to zero.

For any of the known points and measurement points, this procedure can also compute the offset of longitude and latitude of these points relevant to reference line.

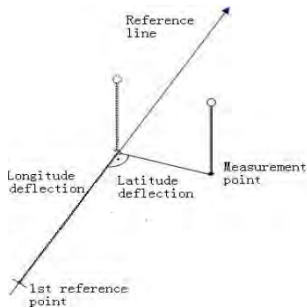

"Line & Offset" Sub-application

The 'Line & Offset' sub-application calculates from measurements or coordinate longitudinal, parallel offsets, and height differences of target point relative to reference line.



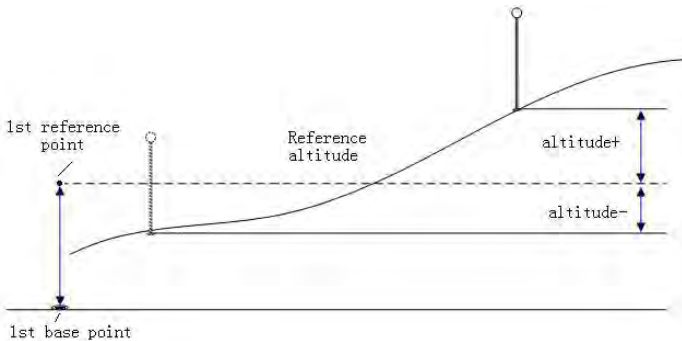

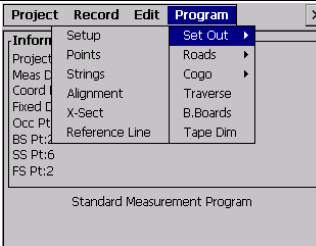
Always calculates the height difference with the height of the first reference point (Δ)

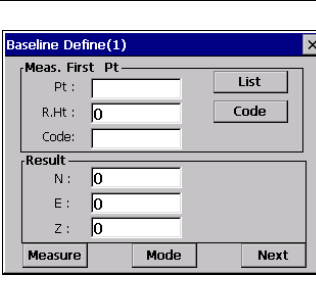

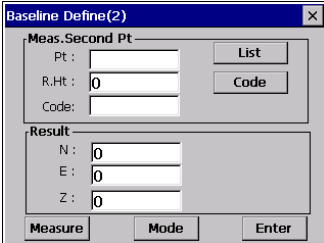
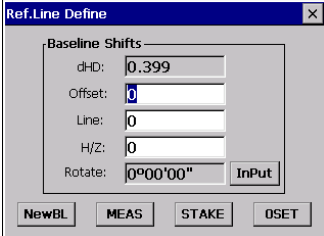
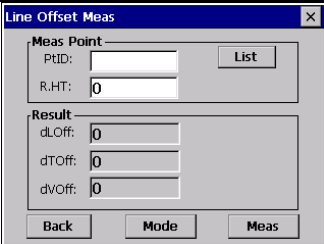
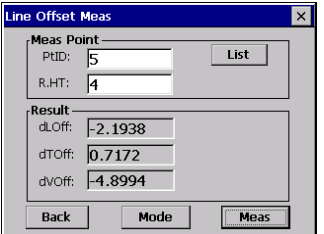
OPERATIONAL STEPS	OPERATION	DISPLAY
<p>① In Programs menu, press [Set Out] to enter "Reference line".</p>	<p>Click "Reference line"</p>	
<p>② Set the station and orientation, (As the method of setting job, station and orientation have been introduced previously; it will not be repeated here.)</p>		
<p>③ There are three methods to define the baseline points, measure directly and call the point from List, and input the coordinates directly.</p>	<p>Input Pt and coordinates, click Next</p>	

<p>④ Define the second point of the baseline.</p>	<p>Input Pt and coordinates , Click Enter</p>	
<p>⑤ Input the offset, Line, H/Z values ,then enter MEAS</p>	<p>Input values, Click MEAS</p>	
<p>⑥ Enter the PtID and R.HT</p>	<p>Input the Pt ID and R.HT</p>	
<p>⑦ Click Meas then get the dLOff, dTOff, dVOff</p>	<p>[Meas]</p>	

Orthogonal Stake-Out

User can enter longitudinal, transverse and height offsets for the target points to be set-out related to the reference line. The program calculates the difference between a measured point and the calculated point. The program displays the orthogonal (pLine, pOffset, p ) and the polar (pHz, Δ , Δ ) differences.

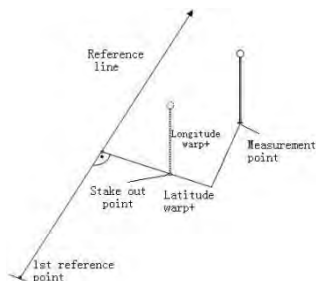

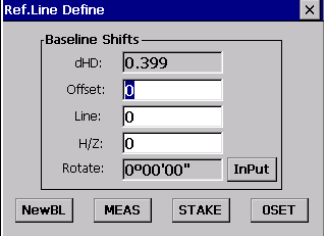
OPERATIONAL STEPS	OPERATION	DISPLAY
<p>① Define the baseline as previous, the third function STAKE to enter Orthogonal Stake-Out.</p>	<p>[STAKE]</p>	

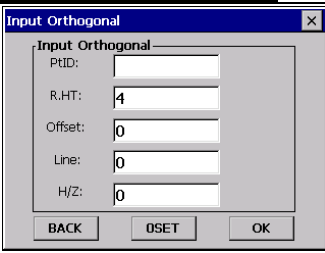
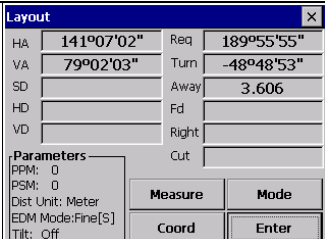
<p>② Input the PtID, R.HT and offset and line, H/Z values.</p>	<p>Inputoffset, line, H/Z, [OK]</p>	
<p>③ Show layout interface, the method have been introduced previously; it will not be repeated here.</p>	<p>[Measure]</p>	

13.2 ROAD DESIGN AND LAYOUT

13.2.1 Define Horizontal Alignment

In [Roads] menu, select[Define HZ AL]. To know how to calculate an alignment, see appendix B.

- Horizontal alignment consisted of following elements: start point, straight line, circular curve and transition curve. First define the start point.

Example:

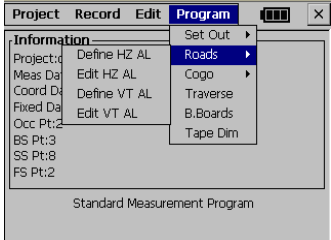
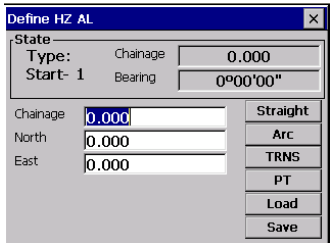
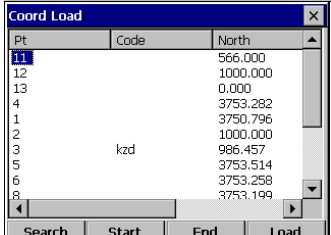
OPERATIONAL STEPS	KEY	DISPLAY																																	
<p>① In [Program] menu, Click [Roads], and then click [Define HZ AL] on the menu popped up.</p>	<p>[Roads]</p>	 <p>The screenshot shows the 'Program' menu with 'Roads' selected. The sub-menu for 'Roads' is open, showing options: 'Define HZ AL', 'Edit HZ AL', 'Define VT AL', and 'Edit VT AL'. Other menu items include 'Set Out', 'Cogo', 'Traverse', 'B.Boards', and 'Tape Dim'. The window title is 'Standard Measurement Program'.</p>																																	
<p>② First, input the details of start point and end point: Chainage, N, and Z.</p> <p>A: They can be input manually.</p> <p>B: For N, E, click [Load] to load data from the project.</p>		<p>A :</p>  <p>The 'Define HZ AL' dialog box shows 'Type' set to 'Chainage' with a value of '0.000' and 'Start- 1' set to 'Bearing' with a value of '0°00'00"'. Below are input fields for 'Chainage', 'North', and 'East', all containing '0.000'. On the right, there are buttons for 'Straight', 'Arc', 'TRNS', 'PT', 'Load', and 'Save'.</p> <p>B:</p>  <p>The 'Coord Load' dialog box shows a table of points with columns for 'Pt', 'Code', and 'North'. Point 11 is selected.</p> <table border="1" data-bbox="573 875 921 1118"> <thead> <tr> <th>Pt</th> <th>Code</th> <th>North</th> </tr> </thead> <tbody> <tr><td>11</td><td></td><td>566.000</td></tr> <tr><td>12</td><td></td><td>1000.000</td></tr> <tr><td>13</td><td></td><td>0.000</td></tr> <tr><td>4</td><td></td><td>3753.282</td></tr> <tr><td>1</td><td></td><td>3750.796</td></tr> <tr><td>2</td><td></td><td>1000.000</td></tr> <tr><td>3</td><td>kzd</td><td>986.457</td></tr> <tr><td>5</td><td></td><td>3753.514</td></tr> <tr><td>6</td><td></td><td>3753.258</td></tr> <tr><td>8</td><td></td><td>3753.199</td></tr> </tbody> </table> <p>Buttons at the bottom: Search, Start, End, Load.</p>	Pt	Code	North	11		566.000	12		1000.000	13		0.000	4		3753.282	1		3750.796	2		1000.000	3	kzd	986.457	5		3753.514	6		3753.258	8		3753.199
Pt	Code	North																																	
11		566.000																																	
12		1000.000																																	
13		0.000																																	
4		3753.282																																	
1		3750.796																																	
2		1000.000																																	
3	kzd	986.457																																	
5		3753.514																																	
6		3753.258																																	
8		3753.199																																	

<p>③ After inputting information of start point; click [Save] to save. Then enter into the screen of alignment input process. As shown on the right.</p>	<p>[Save]</p>	
--	---------------	--

The “Define HZ AL” displays current chainage and the bearing angle (the tangent line from the chainage) and the function key (For creating new line). System provides four functions: defining straight line, circular curve, transition curve, point. Select a function key, enter the detailed information of the chainage, the alignment elements will be created. Click [Save], the new chainage and bearing angle will be calculated automatically and the main alignment screen will be restored. Now other line style can be defined. Press ESC to exit current screen. To modify the element which entered in advance, you should enter the “Edit Alignment” option, the new elements can be added only in the end of the original alignment file.

Straight line

When the start point or other line style is well-defined, it allows you to define straight line. A straight line consists of bearing angle and distance; the distance value can not be minus.

Example:

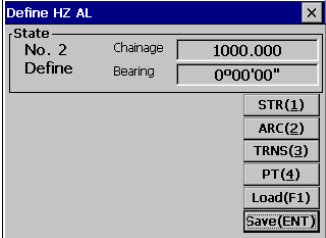
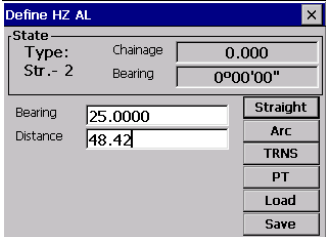
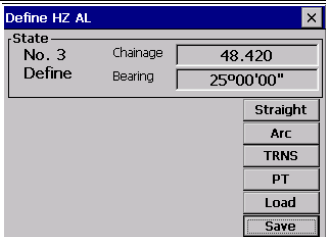
OPERATIONAL STEPS	KEY	DISPLAY
<p>① On the screen of input process, click [Straight], the screen will display factors of straight line to be defined.</p>	<p>[Straight]</p>	
<p>② Input the bearing and length of the straight line.</p>	<p>Input bearing and distance.</p>	
<p>③ Click [Save] and display the chainage of the end of the line and its bearing. You can define other arcs. When the straight line is in the midst of the lignment, the bearing of the straight line is calculated on the base of previous factors. You can input a new bearing manually.</p>	<p>[Save]</p>	

Circular Curve

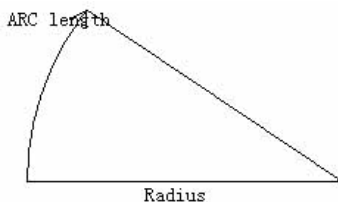

Click [ARC] in the “Define HZ AL”, the circular curve can be defined. Circular curve consists of Arc length and Radius. The rule of radius value: along the forward direction of the curve. When the curve rotates to right, the radius value is positive. When the curve rotates to left, the radius value is minus. The arc length can not be minus.

Example:

OPERATIONAL STEPS	KEY	DISPLAY
<p>① On the screen of input process, click [ARC]. The screen will display the factors of arc to be defined.</p>	<p>[ARC]</p>	<p>The screenshot shows a software window titled 'Define HZ AL'. It contains the following fields and controls:</p> <ul style="list-style-type: none"> Type: Arc-3 Chainage: 10999.000 Bearing: 56°47'00" Radius: Input field with '0' entered. Arc Length: Input field with '0' entered. Buttons: Straight, Arc, TRNS, PT, Load, Save.

SOUTH

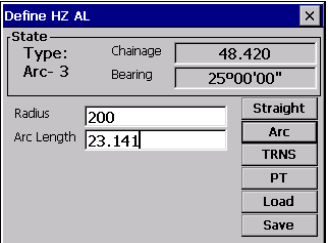
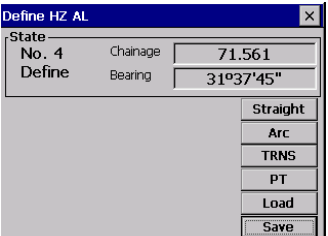
② Input radius and arc length.	Input radius and arc length.	
③ After inputting, click [Save] to save the data of this alignment.	[Save]	

Transition curve

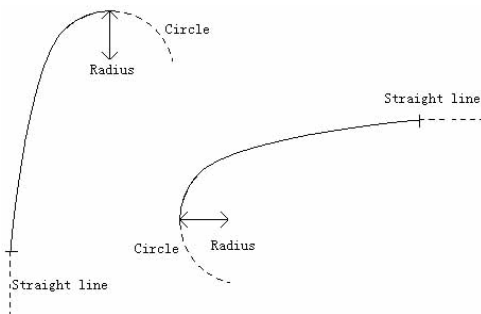

Press [TRNS] key in the “Define HZ AL”, the transition curve can be defined. Transition curve consists of the minimum radius and arc length. The rule of radius

value: along the forward direction of the curve. When the curve rotates to right, the radius value is positive. When the curve rotates to left, the radius value is minus. The arc length can not be minus.

OPERATIONAL STEPS	KEY	DISPLAY
<p>① On the screen of input process, click [TRNS], the screen will display factors of transition curve to be defined.</p>	<p>[TRNS]</p>	
<p>② Input radius and arc length.</p>	<p>Input radius and arc length.</p>	
<p>③ After inputting, click [Save] to save the data of this alignment.</p>	<p>[Save]</p>	

PT (Point)

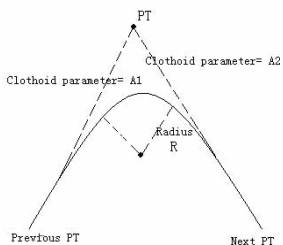

In “Define HZ AL” menu Click [PT], the point can be defined. A point element consists of coordinates, radius and transition curve parameter A1 and A2. Radius, A1 and A2 can not be minus. If radius is entered, an arc is inserted with the specified radius. If transition curve parameter A1 or A2 is entered, a transition curve with the specified length is inserted between straight and arc.

Example:

OPERATIONAL STEPS	KEY	DISPLAY
<p>① On the screen of input process, click [PT], the screen will display factors of point to be defined.</p>	<p>[PT]</p>	

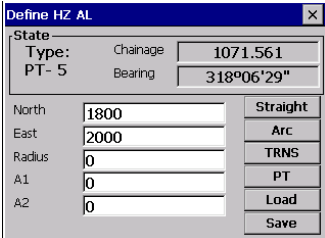
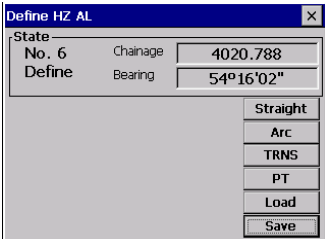
<p>② Input N, E, radius and A1, A2. You can also click [Load] to load coordinate data from the project.</p>	<p>Input coordinate, radius, and arc factors</p>	
<p>③ After inputting, click [Save] to save the data of this alignment.</p>	<p>[Save]</p>	

[NOTE]: When you want to enter A1, A2 from transition curve length L1, L2, the following equations are used:

$$A_1 = \sqrt{L_1 \text{ Radiu}}$$

$$A_2 = \sqrt{L_2 \text{ Radiu}}$$

Any changes to the alignment must be done using the edit alignment option.

SOUTH

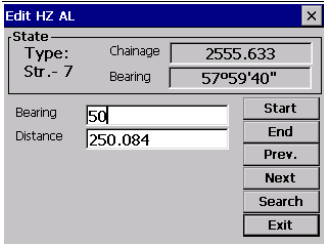
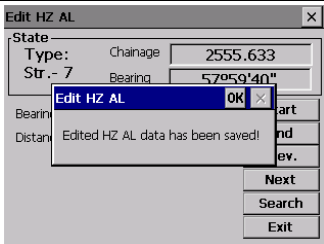
③ System finds the specified chainage, and displays it on the screen. Input new data.		
④ Click any key on the screen, (such as [Next]), the data is saved.		

※1) Start: Press this key to go to the start of the file.

End: Press this key to go to the end of the file.

Prev. : Press this key to display the previous point data.

Next : Press this key to display the previous point data.

Search: Press this key to search for data, after pressing this key, enter the required chainage and press [ENTER], the data for the chainage will be displayed.

[ESC]: Quit the screen.

It is possible to edit data and modify raw data by using above function keys. After entering the data to be modified, click any operation key on the screen key to record the modified data. To exit without saving data, press [ESC] key.

13.2.3 Define Vertical Alignment

A vertical curve consists of series of intersection points. The intersection point consists of a chainage, elevation and curve length. The start and end intersection points must be a zero curve length.

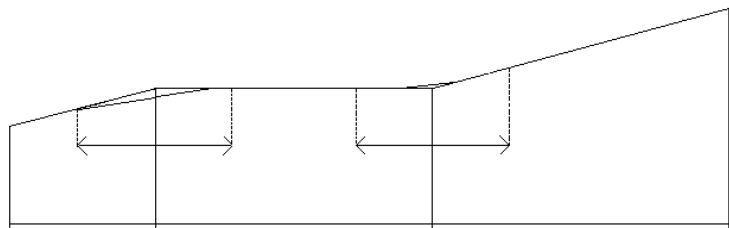

Chainage	1000	1300	1800
	2300		
Elevation	50	70	60
	90		
Curve length	0	300	300
	0		

Intersection points can be entered in any order. After entering a point data, click [Save] to save the point data and enter next one. Press [ESC] to exit without saving.

OPERATIONAL STEPS	KEY	DISPLAY
<p>① In [Roads] menu click [Define VT AL] to enter into defining vertical alignment function.</p>	[Define VT AL]	

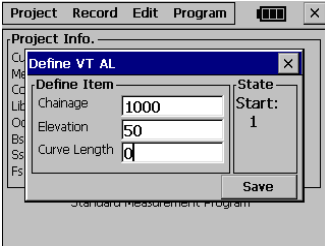
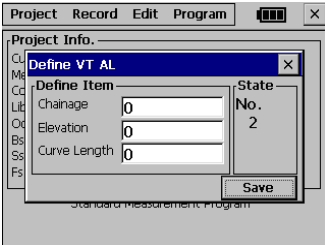
<p>② Input chainage, elevation and Curve Length. After inputting, click [Save]. The curve length of start and end point must be 0.</p>	<p>Input chainage, elevation and Curve Length [Save]</p>	
<p>③ The next defining vertical alignment screen displays. Continue to input next data.</p>		

13.2.4 Edit Vertical Alignment

To modify vertical alignment data, the operational steps are same as editing horizontal alignment data.

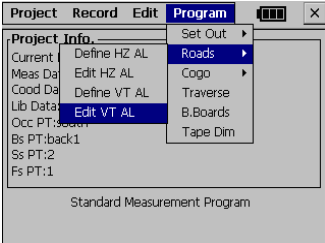
OPERATIONAL STEPS	KEY	DISPLAY
<p>① In [Roads] menu click [Edit VT AL] to enter into defining vertical alignment screen.</p>	<p>[Edit VT AL]</p>	

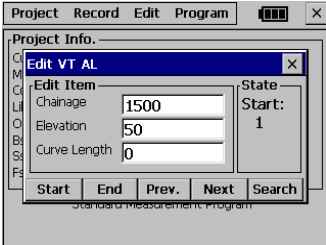
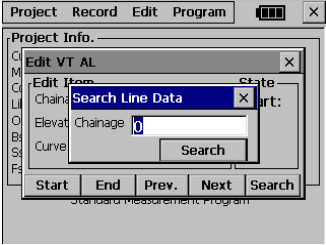
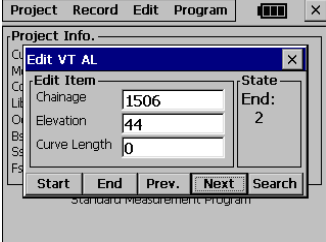
<p>② The screen displays the first alignment data, search the data needs to be edited.</p> <p style="text-align: center;">※1)</p> <p>A: Click Prev. /Next to find the alignment data needed to be edited.</p> <p>B: Click [Search], a dialog box pops up as right graph B. Input chainage and click [Search].</p>		<p>A:</p>  <p>B:</p> 
<p>③ The specified chainage is found and displayed on the screen. Input new data.</p>		

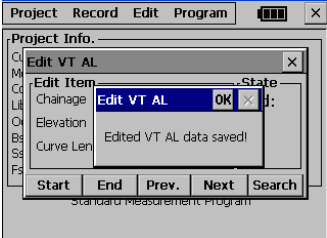
<p>④Click any key on the screen. (Such as [Prev.]), the data is saved.</p>	<p>[Prev.]</p>	
--	----------------	---

13.2.5 Alignment Setout

After setting road data, you can start setting out

For an alignment setout a horizontal alignment must have been uploaded from computer by using [Set Out]→[Alignment].

- the vertical alignment is optional, but is required to cut and fill. The defining method is same as defining horizontal alignment.

Rule:

Offset left: the horizontal distance from the left stake point to the center line.

Offset right: the horizontal distance from the right stake point to the center line.

Elevation difference: Left (right) is the elevation difference between left (right) stake and the center line point.

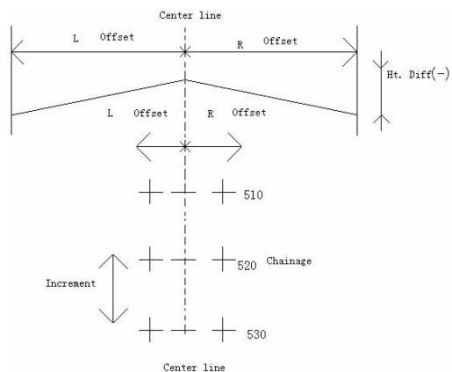

Example:



Please set the occupied point and backsight azimuth firstly.

OPERATIONAL STEPS	KEY	DISPLAY
<p>① In Alignment Layout screen, enter the start chainage, chainage increment, and the horizontal distance from side stake point to center line.</p> <p>To setout dig/fill data, the height difference is needed.</p>		<p>The screenshot shows the 'Alignment Layout' window with the following fields and buttons:</p> <ul style="list-style-type: none"> Setup: Chainage (0), L.offset (0), L.Ht Diff (0), Increment (0), R.offset (0), R. Ht Diff (0). Layout: Chainage (0), Offset (0), Ht Diff (0), R. Ht (0). Buttons: LOFS, ROFS, +CHG, -CHG, Slope, Layout.

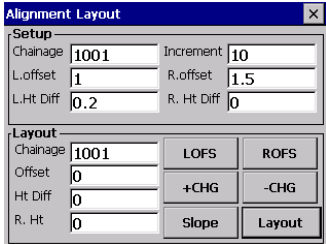
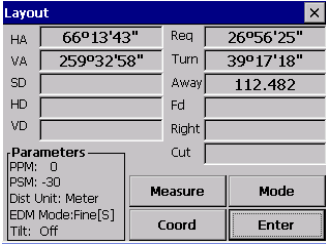
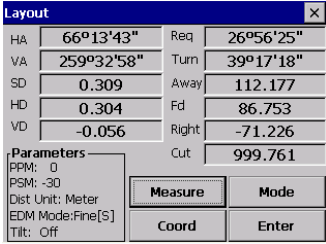
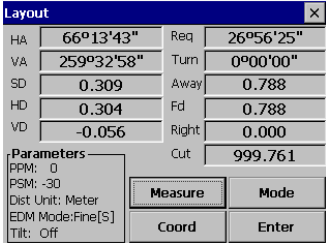
SOUTH

<p>② After inputting, the center line setting out data of the start chainage displays on the lower screen.</p>		
<p>③ Here stipulate: first set out point on center line, and then set out points on left/right chainage.※1) Input prism height, and click [Set Out] to set out.</p>	<p>[Set Out]</p>	
<p>④ Sight the current prism, click [Measure] to start measure and calculate parameter difference between measuring point and setting out point.</p>	<p>[Measure]</p>	
<p>⑤ Rotate the telescope, making "Turn" item and "→" item display as 0, and ask the rodman to move prism.</p>		

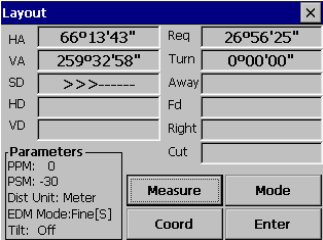
SOUTH

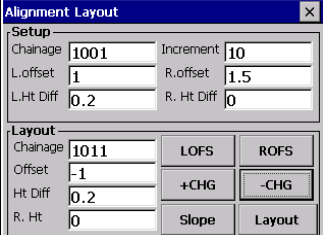
<p>⑥ Sight the prism center, click [Measure] to start measure. Ask the rodman to move prism making “Away” and “↑” display as 0.</p>		
<p>⑦ When four items are 0, the point to be set out is found. “Cut” item indicates the dig/fill value. When it is positive, it means to dig. When it is minus, it means to fill.</p>		
<p>⑧ After finish setting out one point, click [Enter] to quit. The screen returns to Alignment Setout main screen. Click [LOFS]/[ROFS], or +CHG/-CHG, repeat steps ②~⑥ to finish setting out other points. ※1)</p>		
<p>※1) Press [LOFS] (or [ROFS]), corresponding chainage, offset, elevation difference will be displayed on the screen. The chainage and offset can be entered manually. If the offset is minus, the offset point is at the left side to center line. If the offset is positive, the offset point is at the right side to center line.</p>		

Explanation for the main setout screen:

Setup	
Chainage	1001
Increment	10
L.offset	1
R.offset	1.5
L.Ht Diff	0.2
R. Ht Diff	0

Layout	
Chainage	1001
Offset	0
Ht Diff	0
R. Ht	0

Buttons: LOFS, ROFS, +CHG, -CHG, Slope, Layout

LOFS: The key is use to setting out the left side stake. Press it to display the offset and the height difference of the left side stake.

ROFS: The key is use to setting out the right side stake. Press it to display the offset and the height difference of the right side stake.

+CHG: The key is use to increasing the chainage.

-CHG: The key is use to decreasing the chainage.

Slope: The key is used to slope set out.

13.2.6 Slope Setout

Slope setting-out can be performed as part of the Alignment setout option. Only after defining vertical alignment and horizontal alignment, it is possible to perform slope setting-out. In Alignment Layout menu click [Slope] to display slope layout.

Slope layout main menu:

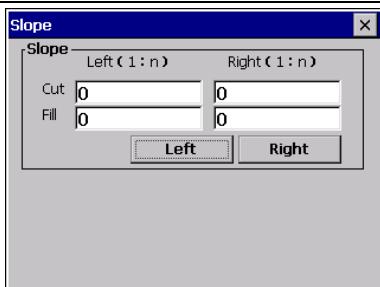

The input cut/fill value is a ratio.

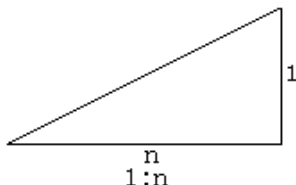

The left and right slopes may be entered for both cut and fill. Enter the required slopes using positive numbers for both cut and fill. The software selects the appropriate slope from the table depending on whether the situation is on the left or right and in excavation or fill.

Excavation or fill is determined by the estimated level at the offset of the hinge point. If the level is above the level of the hinge then the cut slope is used, otherwise the fill slope is used.

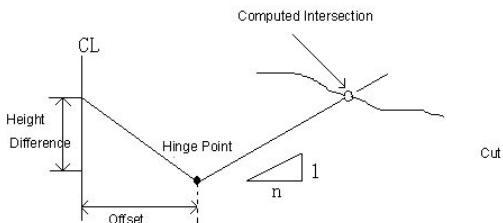

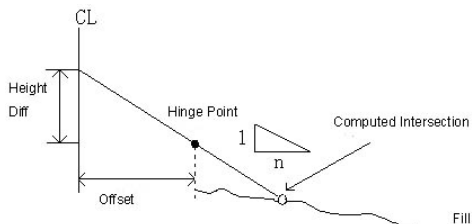

Example:

OPERATIONAL STEPS	KEY	DISPLAY
<p>① Enter (or select) the side chainage needs to precede the slope layout.</p>		
<p>② Click [Slope] to start slope layout. After inputting ratio of dig (or fill) of Left and Right slope After inputting, select left or right slope to layout.</p>	<p>[Slope]</p>	

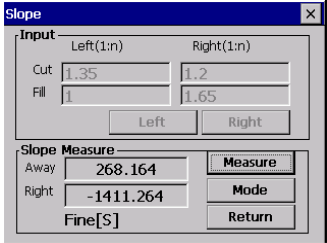
<p>③ Enter the slope layout menu. Input the prism pole and sight a point where it is estimated the slope to intercept and press [Measure] to take the first trial shot. The appropriate slope is selected from the data entered in the preceding step. The first intercept is assuming a horizontal surface at the level of the measured point. The error from measured point to calculated point will display. The layout method of slope is same with point setting out. When the data which display in [→] and [↑] is 0, the setting out</p>	<p>[Measure] e]</p>	
---	-------------------------	---

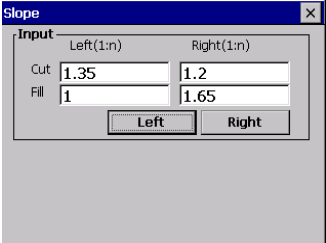
point is found.		
④ After laying out the point, click [Return] to return to slope layout main menu. Input or select other slope to layout and layout as the same method.	[Return]	

[Note]:

- 1) An intersection can not be computed if the ground surface passes through the hinge point.

- 2) The cut is not displayed because the cut at the computed point is zero.

13.2.7 Cross Section Setout

To set out design cross sections select X-Sect from the Set Out menu.

The cross section setout is similar to the alignment setout, the points are uploaded in chainage, offset and level format and a reference alignment must also exist.

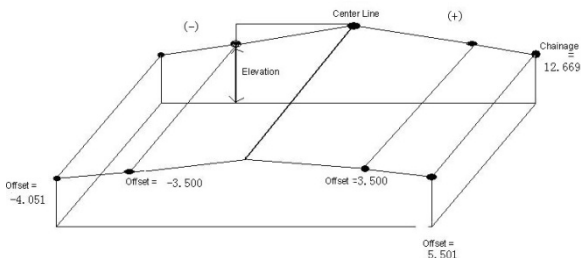

X-Sects layout main menu

Chainage	Offset	Elevation
0.000	-4.501	18.527
0.000	-3.500	18.553
0.000	0.000	18.658
0.000	3.500	18.553
0.000	5.501	18.493
12.669	-4.501	18.029
12.669	-3.500	18.059
12.669	0.000	18.164

Chainage	0	Offset	-4.501	Slope
Ht Diff	18.527	R.Ht	1.58	Layout
LOFS	ROFS	+CHG	-CHG	

The screen displays cross section data imported to total station. About the method please refer to “10.2 DATA IMPORT”. Example:

OPERATIONAL STEPS	KEY	DISPLAY
① In the menu of Set Out, click [X-Sect].		<p>The screenshot shows the 'Program' menu with 'X-Sect' highlighted. Other options include Setup, Points, Strings, Alignment, X-Sect, Occ Pt:111, BS Pt:110, SS Pt:105, FS Pt:114, Roads, Cogo, Traverse, B.Boards, and Tape Dim.</p>

<p>② Data will display on the screen.</p>		
<p>③ Click FNC Key [+CHG]/[-CHG] to search data forward or backward; click [LOFS]/[ROFS] to display neighboring offset and elevation on the cross section.</p>	<p>[+CHG]/[-CHG] [LOFS]/[ROFS]</p>	
<p>④ Select the chainage and input the prism height of the target. Then click [Set Out] to start setting out. The method of setting out is the same as that of alignment.</p>	<p>[Set Out]</p>	

※The HeightDifference value is elevation value here. (Different to Horizontal Alignment Setting out)

[Note]: Cross Section data can not be entered nor edited by manual input; it has to be copied into WIN total station.

OPERATIONAL STEPS:

- 1) Create a new text file (.txt) on the computer and save it. See Appendix A for the format of cross section data.
- 2) Copy the file to total station.
In the total station, import the saved data to current project by “Data Import”.
See “10.2 Data Import”.
- 3) You can use [LOFS]/[ROFS] to display appointed chainage. The sequence of the displayed data is according to the sequence in text file. Enter data in the order of its offset values (from left to right), if chainages are the same.
- 4) When editing the cross section data, chainages should be in the order from little to much.

13.3 COGO

The COGO menu contains a number of coordinate geometry functions. (Fixed point data can not be used in these functions).

Intersection

4-points intersections

Inverse

Area

Radiation

Missing line Measurement

13.3.1 Intersection

The coordinate for a point can be computed by the intersection of two known bearings.

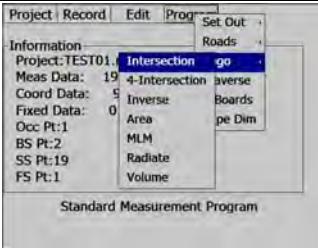
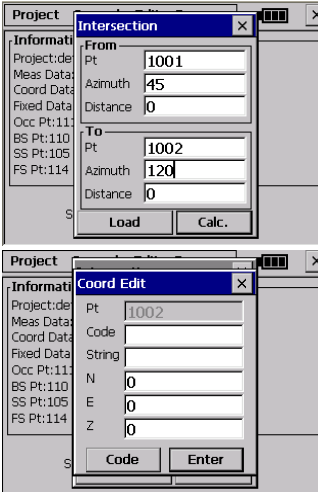
OPERATIONAL STEPS	KEY	DISPLAY
<p>① In [Program] menu, click [Cogo]. And click [Intersection] in Cogo menu.</p>	<p>[Cogo] [Intersection]</p>	
<p>② In pop-up dialog input the point ID and azimuth/distance of point A, B that are applied in intersection. Here take azimuth intersection for example., ※1)、 ※2)</p> <p>If the point ID input does not exist in the project, an inputting dialog will display as shown on the right. Input the coordinate, and click [Enter] to save.</p>		

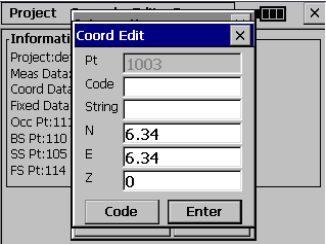
<p>③ After inputting, click [Calc.], the system calculate the coordinate of the intersection.</p> <p>If there's no intersection, it displays "No intersection error".</p> <p>Input the point ID, and click [Enter].</p>	[Calc.]	
<p>④ Data is saved. The display returns to standard survey main menu.</p>		
<p>※1) PT: The number of intersection point.</p> <p style="padding-left: 20px;">Azimuth: The azimuth from occupied point to intersection point direction.</p> <p style="padding-left: 20px;">Distance: The distance from occupied point to intersection point.</p> <p>※2) To call up coordinate data from project, you can click [Load].</p>		

[NOTE]:

If intersection is not in the specified bearing, the software creates the intersection point backward.

The intersection point can not be saved, if the coordinates are not in the allowed range

13.3.2 4-Intersection

The coordinate for a point can be computed by the intersection of four known points.

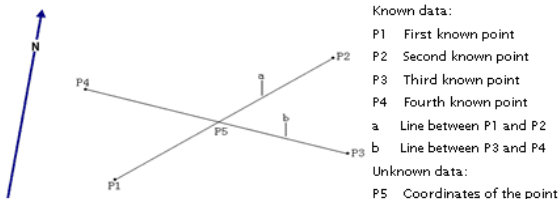

OPERATIONAL STEPS	KEY	DISPLAY
<p>① In COGO menu click [4-Intersection].</p>	<p>[4-Intersection]</p>	
<p>② In the popped up dialog box enter the points used for 4-Intersection. If the entered PT doesn't exist in project, program will request you to enter coordinates. ※1)</p>		

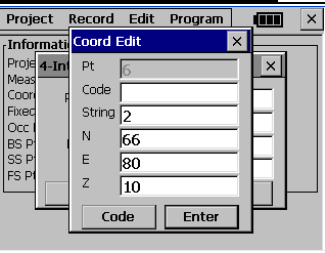
<p>③ After inputting, click [Calc.], to calculate the coordinates of intersection point.</p> <p>If no intersection exists, “No Intersection!” will display.</p> <p>Input the point name and click [Enter]</p>	<p>[Calc.]</p>	
<p>④ The data is saved and the display returns to standard survey main menu.</p>		
<p>※1) To call coordinate data from project, Click [Load].</p>		

[NOTE]:

- 1) If there is no intersection point, the message “No Intersection” will be displayed.
- 2) If intersection is not in the specified bearing, the software creates the intersection point backward.
- 3) The intersection point can not be saved, if the coordinates are not in the allowed range.

13.3.3 Inverse

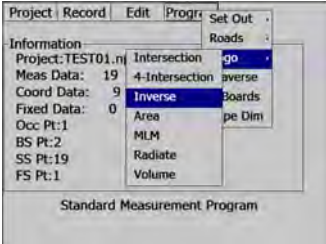
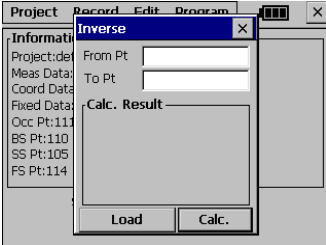
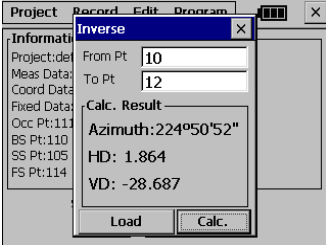
OPERATIONAL STEPS	KEY	DISPLAY
<p>① In COGO menu click [Inverse].</p>	[Inverse]	 <p>The screenshot shows the 'Standard Measurement Program' window. The 'Edit' menu is open, and 'Inverse' is highlighted. Other options include 'Intersection', '4-Intersection', 'Area', 'MLM', 'Radiate', and 'Volume'. The background window shows project information like 'Project: TEST01.n', 'Meas Data: 19', 'Coord Data: 9', etc.</p>
<p>② Enter From PT and To PT. If the entered PT doesn't exist in project, program will request you to enter coordinates.※1)、※2)</p>		 <p>The screenshot shows the 'Inverse' dialog box. The 'From Pt' and 'To Pt' fields are empty. The 'Calc. Result' section is also empty. There are 'Load' and 'Calc.' buttons at the bottom.</p>
<p>③ After inputting, click [Calc.], to calculate the coordinates ※3)</p>	[Calc.]	 <p>The screenshot shows the 'Inverse' dialog box with calculated results. The 'From Pt' is 10 and 'To Pt' is 12. The 'Calc. Result' section shows: 'Azimuth: 224°50'52"', 'HD: 1.864', and 'VD: -28.687'. There are 'Load' and 'Calc.' buttons at the bottom.</p>
<p>④ Press [ESC] to return to standard survey main menu.</p>	[ESC]	
<p>※1) To call coordinate data from project, Click [Load].</p> <p>※2) From PT: Pt shows start from which point. To PT: Pt shows finish at which point.</p>		

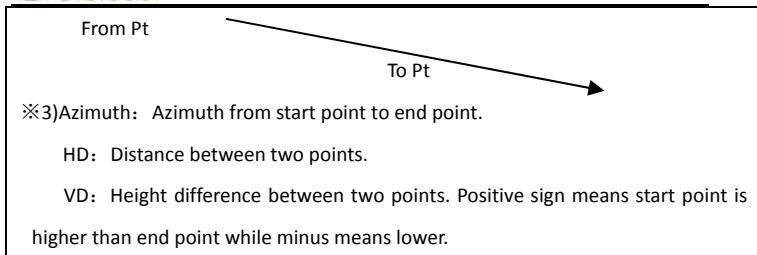

13.3.4 Area

The points used to calculate area can be gained in two ways: use specified points or points with a common coding.

13.3.4.1 Area Using Specified Points

An area can be calculated by marking at least 3 points.

Example:

OPERATIONAL STEPS	KEY	DISPLAY
①In COGO menu click [Area].	[Area]	

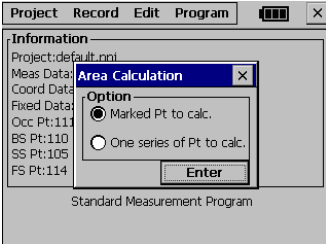
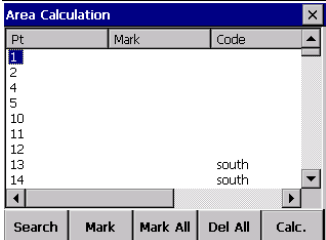
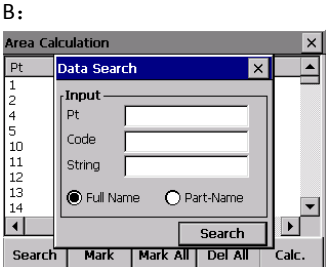
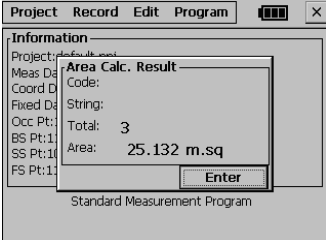
<p>② A dialog box pops up. Click “Marked Pt to Calculate” and click [Enter]. ※1)</p>	<p>[Enter]</p>	
<p>③</p> <p>A: Click [Mark] to mark pts used for area calc. ※2)</p> <p>B: You can click [Search] to search PT in project.</p>	<p>[Mark]</p> <p>Search</p>	<p>A:</p>  <p>B:</p> 
<p>④ Click [Calc.] to calculate the area. The number used to calculate and area will be shown. ※3)、※4)</p>	<p>[Calc.]</p>	

⑤Click [Enter] to quit and return to Standard Survey Main Menu.	[Enter]	
<p>※1) Marked Pt to Calc.: specify which points should be used for the area calculation</p> <p>One kind of Pt to Calc: Compute the area of a figure enclosed by points with a common coding.</p> <p> ※2)[Search]: Search the required point number data in data file.</p> <p> [Mark]: Mark the points to be used in area calculation</p> <p> [Mark All]: Mark all points in project, and use them to calc.</p> <p> [Del All]: Delete all marks</p> <p>※3)Total: The number of the points which is used in area calculation</p> <p> Area: The enclosed area of the points which is used in area calculation</p> <p>※4) An area can be calculated by marking at least 3 points If less than 3 pts the program will prompts "At least 3 Pts are required!")</p>		

13.3.4.2 Area Calculation by Using Code

The area of a figure enclosed by points with a common coding can be computed.

When recording points observe them in the correct sequence and give each point the same point code.

Example:

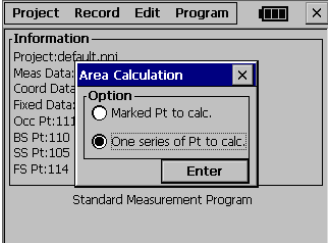
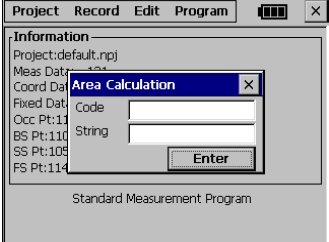
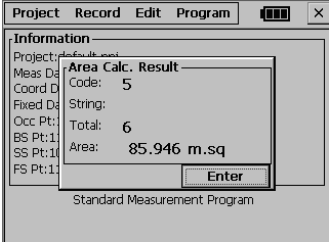
OPERATIONAL STEPS	KEY	DISPLAY
① In Area Option, click “One kind of Pt to calc”, and click [Enter]. ※1)	[Enter]	
② Input Code and String used for area. Click [Enter].	[Enter].	
③ The program will search data meets the requirement and calculate the area.		
④ Click [Enter] to quit and return to Standard Survey Main Menu.	[Enter]	

Usually (m^2) or (ft^2) is used as a unit for an area. If the area is larger than 10000m.sq then the unit is changed to Ha (hectare). The unit is changed to AC

(acre) if the closed area is 43560ft.sq or more.

[NOTE]: Area is not calculated correctly if enclosed lines cross each other.

If less than 3 points are found which have been marked the software will show the message "3 PTS required".

The data in fixed points file can not be used in this program.

13.3.5 Missing Line Measurement

This function can be used to calculate the length of a line by measuring the start and end point of this line. You should set the occupied points and backsight azimuth before the measurement.

Example:

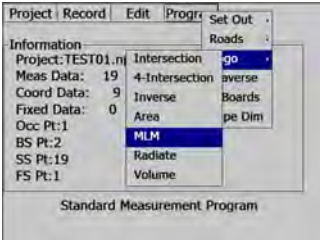
OPERATIONAL STEPS	KEY	DISPLAY
① In Area Option, click [MLM]	[MLM]	

② Input the Pt used for
MLM measurement. ※1)

(If occupied point and
Backsight azimuth has not
been defined, the dialog box as
right will pops up.)

If the entered point doesn't
exist in project, program will
request you to measure this
point.

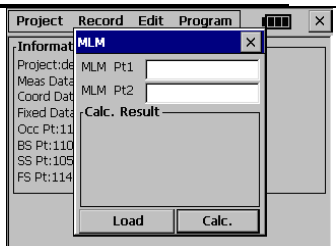

Set Occ.& BSpont:

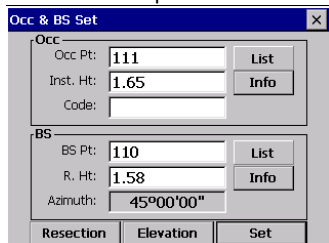

Pt does not exist inproject:

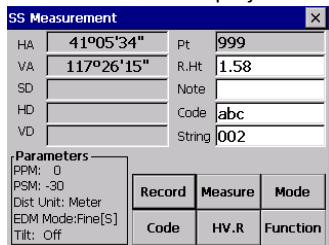

<p>③ The result is calculated out and displayed.</p> <p>dHd: Horizontal distance between the two points.</p> <p>dVd: Height difference between two Points;</p> <p>dSd: Slope distance between two points.</p>		
<p>④ Press [ESC] to quit and return to Standard Survey Main Menu.</p>	<p>[ESC]</p>	
<p>※1) To call coordinate data from project, Click [Load].</p>		

[Note]: dVd is defined as the height of the second point minus the height of the first point. Due to this reason dVd can be negative.

dSd is defined as the length of the missing line.

dHd is defined as the length of the projected missing line in the horizontal plane. dSd and dHd are always positive.

13.3.6 Radiate

The coordinate for a point can be computed by entering the Azimuth and Distance.

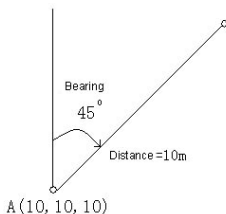

Example:

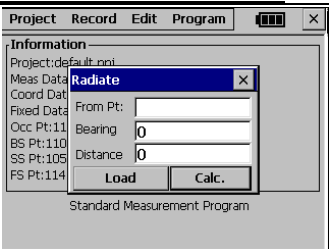
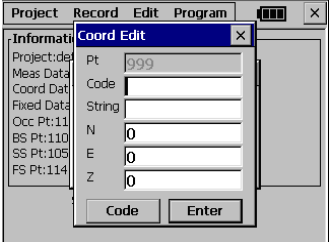

OPERATIONAL STEPS	KEY	DISPLAY
<p>① In COGO menu click [Radiate].</p>	<p>[Radiate]</p>	

<p>② Input From PT, Bearing and Distance, and click [Calc.]. ※1)</p> <p>If the entered PT doesn't exist in project, program will request you to enter coordinates.</p> <p>After inputting, click [Enter] to calculate.</p>	<p>[Calc.]</p>	
<p>③ the new point coordinate will be calculated and be displayed. ※2)</p>		
<p>※1) To call coordinate data from project, Click [Load].</p> <p>※2) Elevation value can not be calculated, only can be manually input, the results is stored in coordinates data files.</p>		

13.3.7 Volume

This function can be used to calculate the volume of a base area by setting the height.

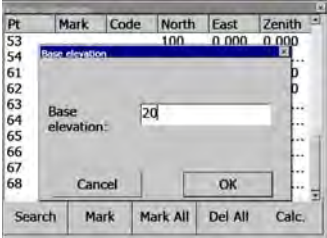
OPERATIONAL STEPS	KEY	DISPLAY																																																																																																																																				
<p>① In COGO menu click [Volume].</p>	<p>[Volume]</p>																																																																																																																																					
<p>② Select base area PTand click [Mark.].)</p>	<p>[Mark]</p>	<table border="1" data-bbox="588 598 930 841"> <thead> <tr> <th>Pt</th> <th>Mark</th> <th>Code</th> <th>North</th> <th>East</th> <th>Zenith</th> </tr> </thead> <tbody> <tr><td>53</td><td></td><td></td><td>100...</td><td>0.000</td><td>0.000</td></tr> <tr><td>54</td><td></td><td></td><td>100...</td><td>100...</td><td>100...</td></tr> <tr><td>61</td><td></td><td></td><td>0.000</td><td>0.000</td><td>0.000</td></tr> <tr><td>62</td><td></td><td></td><td>100...</td><td>0.000</td><td>0.000</td></tr> <tr><td>63</td><td></td><td></td><td>100...</td><td>100...</td><td>100...</td></tr> <tr><td>64</td><td></td><td></td><td>0.000</td><td>100...</td><td>100...</td></tr> <tr><td>65</td><td></td><td></td><td>0.000</td><td>0.000</td><td>100...</td></tr> <tr><td>66</td><td></td><td></td><td>100...</td><td>0.000</td><td>100...</td></tr> <tr><td>67</td><td></td><td></td><td>100...</td><td>100...</td><td>100...</td></tr> <tr><td>68</td><td></td><td></td><td>0.000</td><td>100...</td><td>100...</td></tr> </tbody> </table> <table border="1" data-bbox="588 856 930 1089"> <thead> <tr> <th>Pt</th> <th>Mark</th> <th>Code</th> <th>North</th> <th>East</th> <th>Zenith</th> </tr> </thead> <tbody> <tr><td>53</td><td></td><td></td><td>100...</td><td>0.000</td><td>0.000</td></tr> <tr><td>54</td><td></td><td></td><td>100...</td><td>100...</td><td>100...</td></tr> <tr><td>61</td><td>Marked</td><td></td><td>0.000</td><td>0.000</td><td>0.000</td></tr> <tr><td>62</td><td>Marked</td><td></td><td>100...</td><td>0.000</td><td>0.000</td></tr> <tr><td>63</td><td>Marked</td><td></td><td>100...</td><td>100...</td><td>100...</td></tr> <tr><td>64</td><td></td><td></td><td>0.000</td><td>100...</td><td>100...</td></tr> <tr><td>65</td><td></td><td></td><td>0.000</td><td>0.000</td><td>100...</td></tr> <tr><td>66</td><td></td><td></td><td>100...</td><td>0.000</td><td>100...</td></tr> <tr><td>67</td><td></td><td></td><td>100...</td><td>100...</td><td>100...</td></tr> <tr><td>68</td><td></td><td></td><td>0.000</td><td>100...</td><td>100...</td></tr> </tbody> </table>	Pt	Mark	Code	North	East	Zenith	53			100...	0.000	0.000	54			100...	100...	100...	61			0.000	0.000	0.000	62			100...	0.000	0.000	63			100...	100...	100...	64			0.000	100...	100...	65			0.000	0.000	100...	66			100...	0.000	100...	67			100...	100...	100...	68			0.000	100...	100...	Pt	Mark	Code	North	East	Zenith	53			100...	0.000	0.000	54			100...	100...	100...	61	Marked		0.000	0.000	0.000	62	Marked		100...	0.000	0.000	63	Marked		100...	100...	100...	64			0.000	100...	100...	65			0.000	0.000	100...	66			100...	0.000	100...	67			100...	100...	100...	68			0.000	100...	100...
Pt	Mark	Code	North	East	Zenith																																																																																																																																	
53			100...	0.000	0.000																																																																																																																																	
54			100...	100...	100...																																																																																																																																	
61			0.000	0.000	0.000																																																																																																																																	
62			100...	0.000	0.000																																																																																																																																	
63			100...	100...	100...																																																																																																																																	
64			0.000	100...	100...																																																																																																																																	
65			0.000	0.000	100...																																																																																																																																	
66			100...	0.000	100...																																																																																																																																	
67			100...	100...	100...																																																																																																																																	
68			0.000	100...	100...																																																																																																																																	
Pt	Mark	Code	North	East	Zenith																																																																																																																																	
53			100...	0.000	0.000																																																																																																																																	
54			100...	100...	100...																																																																																																																																	
61	Marked		0.000	0.000	0.000																																																																																																																																	
62	Marked		100...	0.000	0.000																																																																																																																																	
63	Marked		100...	100...	100...																																																																																																																																	
64			0.000	100...	100...																																																																																																																																	
65			0.000	0.000	100...																																																																																																																																	
66			100...	0.000	100...																																																																																																																																	
67			100...	100...	100...																																																																																																																																	
68			0.000	100...	100...																																																																																																																																	

<p>③ Click[Calc.] to setting target volume height and Click[OK] to get the result</p>	<p>[Calc.] [OK]</p>	
<p>④ +Volume means volume above target height -Volume means volume below target height Total means above volume balanced with below volume.</p>		

13.4 TRAVERSE ADJUSTMENT

The Bowditch (compass rule) adjustment method is used to adjust a recorded traverse. The traverse is defined by entering start and end points and the intermediate points are determined from foresight observations. The coordinates for the start and end points must be known.

- If the coordinates of the initial BKS PT are known, the software calculates the bearing from the point data.
- The foresight option must be used to record observations to the traverse points and the observed end point must have a different point number to the known point.

- To adjust angles the end point must be occupied and a known point observed to measure the closing angle. The point number used for this observation must be different from the known point too.

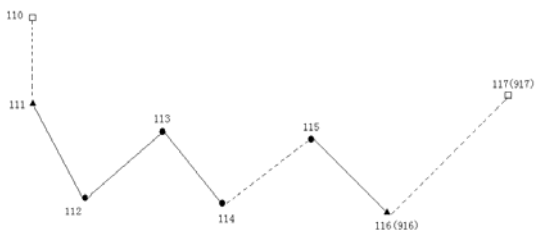

Start Pt: 111 BKS Pt: 110 End Pt: 116 Close Pt: 117

Known Pt: 110 111 916 917

Example:

1. Measurement

OPERATIONAL STEPS	KEY	DISPLAY
<p>① Select a known point and set up the instrument on the point. (For example Pt 111) Set pt 110 as back sight point. After setting, click [Set].</p>	<p>[Set]</p>	<p>The screenshot shows the 'Occ & BS Set' dialog box with the following fields and values:</p> <ul style="list-style-type: none"> Occ: Occ Pt: 111, Inst. Ht: 1.65, Code: (empty) BS: BS Pt: 110, R. Ht: 1.5, Azimuth: 45°00'00" Buttons: Resection, Elevation, Set

<p>② Program calculates out the Backsight azimuth, click [Setup] to set current horizontal as the Backsight azimuth, and click [Enter].</p>	<p>[Setup]</p> <p>[Enter]</p>	
<p>③ In [Record] menu click [FSObs].</p>	<p>[Record]</p> <p>[FSObs]</p>	
<p>④ Sight the traverse point 112, use [Record] to record the measured coordinates.</p>	<p>[Record]</p>	

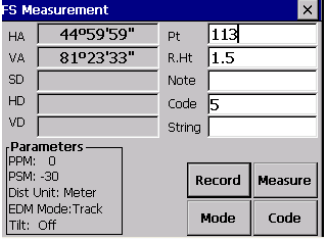
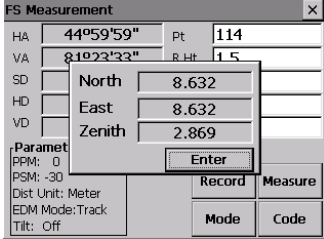

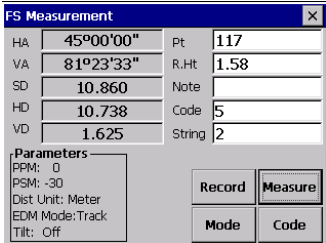
<p>⑤ Move the instrument to PT112. Turn on the machine and select [Record], re-measure occupied point (PT112), backsight point (PT111), sight traverse point (PT113).Click record.</p>	<p>[Record]</p>	
<p>⑥ Repeat ①~④ to measure and record coordinates of each traverse point. (The number of traverse point is entered according to length and requested accuracy).</p>		
<p>⑦ When the instrument is moved to PT115, measure a known point (916), record as PT116.</p>		

<p>⑧ To calculate traverse, you should set station on PT116, and sight another known point (such as 917), measure and record as PT117. Here the PT117 is the closing point.</p>	
---	---

2. Adjustment:

If the closure point is measured: (The step 1, 2 are same as above).

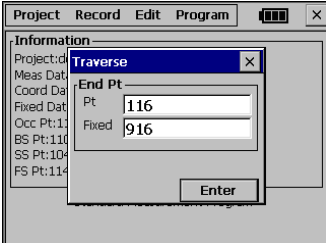
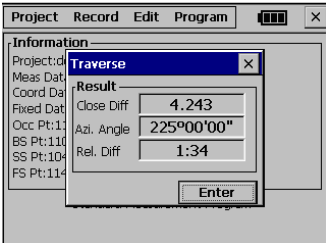
OPERATIONAL STEPS	KEY	DISPLAY
<p>③ After entering Start Pt, system prompts to enter End Pt (Measured Point number) and the known Pt, these two points should be different.</p>		

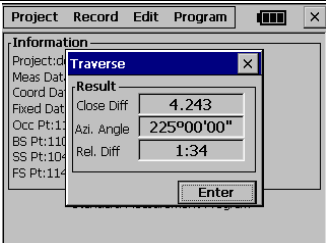
<p>④ Enter Close Pt (Measured Point number) and the known Pt, these two points should be different too.</p>		
<p>⑤ The close difference is calculated and displayed. Click [Enter].</p>	<p>[Enter]</p>	
<p>⑥ The azimuth results display. If the angle is in the allowed range of close difference, click [Enter].</p>	<p>[Enter]</p>	
<p>⑦ the system calculates angle adjustment and displays the result. Click [Enter].</p>	<p>[Enter]</p>	

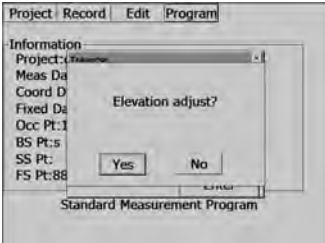
<p>⑧ Here the screen pops up “Coord Adjust” Press [Yes] to adjust Not to change any data, click [No]</p>	<p>[Yes] or [No]</p>	
<p>⑨ The screen pops up “Elevation Adjust” again. Click [Yes] to adjust. Not to change any data, click [No]</p>	<p>[Yes] or [No]</p>	
<p>⑩ The display returns to standard survey main menu.</p>		

13.5 BATTER BOARDS

When setting out points, particularly for building plots, it is usually necessary to mark a point with an offset so that the point can be re-established after work has been carried out in the work area. In this case batter board can be used: the intersection point (of a batter board and the line that connects

two points that have to be set out) can be marked. Later, the intersection points are used by pulling a string line between these points. In this way, the required points can be reconstructed.

- There are two ways to proceed:

First way is using two sides of the batterboard. The user is advised to use this method in case high accuracy is required, control of the measurements is required or one batterboard is used to mark more than one intersection point. Refer to Chapter 13.5.1.

Second way is using one side of the batterboard. The user is advised to use this method in case a quick method is required. Refer to Chapter 13.5.2.

13.5.1 Method 1: Batter board using two sides

The two sides of batterboard should be measured now. Put the reflector above one side of the batterboard, enter a number for this point (BB point 2) and press Enter.

Operating Procedure:

Two setout point (S1 and S2) are selected and one side of the batterboard is measured (BB1).

The other side of the batterboard is measured (BB2). The intersection point of the batterboard and the line connecting S1 and S2 is calculated. Next, the distance (D1) from BB1 to

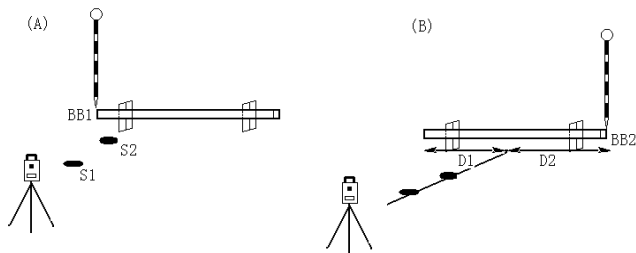

intersection point and the distance (D2) from BB2 to intersection point are calculated.

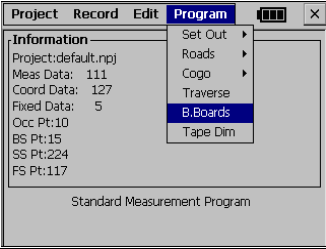
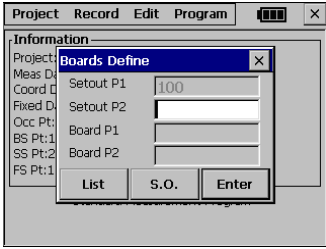
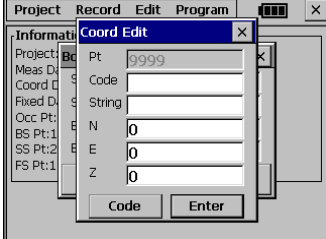

Example:

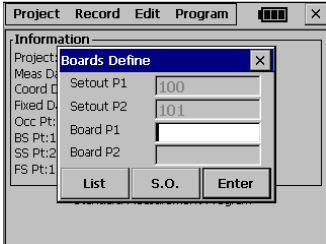
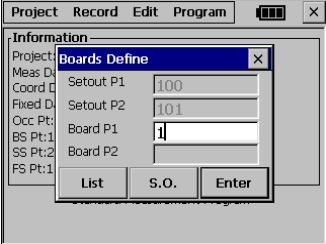
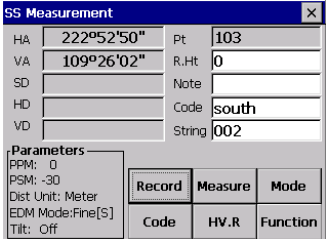
OPERATIONAL STEPS	KEY	DISPLAY
<p>① In [Program] menu, click [B.Boards].</p>	<p>[B.Boards]</p>	
<p>②</p> <p>A: Input Setout P1 and click [Enter].</p> <p>B: If the Point is unknown, a dialog box will pop up to request you to enter the coordinates. After inputting, click [Enter].</p>	<p>[Enter]</p>	<p>A:</p>  <p>B:</p> 

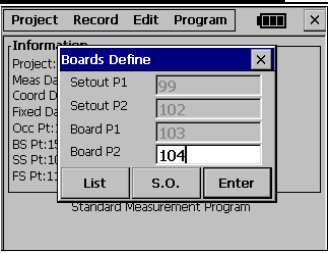
<p>③ Enter Setout P2 and click [Enter].</p>	<p>[Enter]</p>	
<p>④</p> <p>A Now define the batter board, enter Board 1 and click [Enter].</p> <p>B If the point is unknown, SS Measurement dialog box will pop up. After measuring, the data is record to the project.</p>		<p>A:</p>  <p>B:</p> 

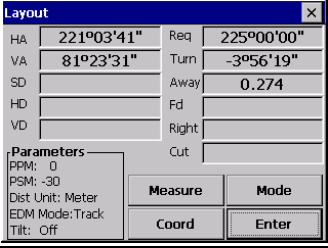
<p>⑤ Enter Board 2.</p>		
<p>⑥ A dialog box shows the distances from intersection to PT1 and PT 2. ※1)</p>		
<p>⑦ Click "Yes", the intersection is set out.</p>		
<p>※1) Click "X" to quit batter board program.</p>		

※The setout of this intersection point is identical to Point Setout, which is discussed in paragraph 13.1.3, except for two differences.

Automatically the intersection point is chosen for setting out.

CUT is not shown at the screen.

NOTE:

If the intersection point is not on the batterboard, the message “Point Not on Batterboard!” is shown on the screen.

In case a batterboard is used twice and its position hasn't changed, it is not necessary to re-measure the sides of the batterboard. Use the same number for the sides of the batterboard.

The error message “Invalid value ! ”is shown if the batterboard and the line connecting the two setout points are parallel.

The coordinates of the calculated intersection point are recorded in the coordinate file. The number of this intersection point is, compared to the highest existing number, incremented by one.

13.5.2 Method 2: Batterboards using one side

Click [S.O.] in case you want to measure only one side of the batterboards.

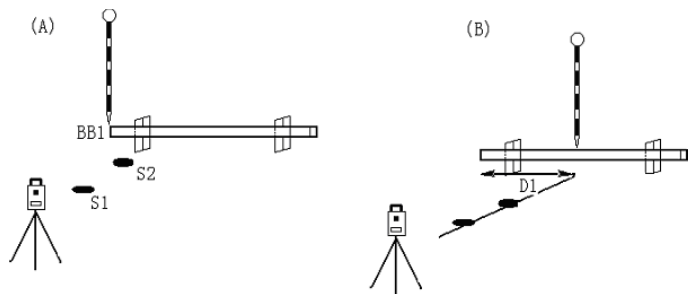

Operating procedure :

Two setout points (S1 and S2) are selected and one side of the batterboard is measured (BB 1). An approximate distance D1 is shown.

The position of the pole is changed according to the value of D1 and a

measurement is performed. The distance D1 is now precise. The process has to be repeated until D equals zero to find the intersection point.

Example:

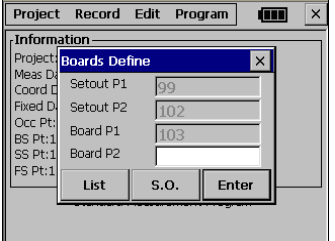
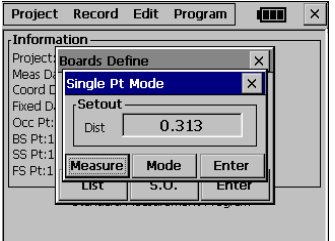
OPERATIONAL STEPS	KEY	DISPLAY
<p>① After entering Setout Points and Board1 click [S.O].</p>	<p>[S.O]</p>	
<p>② Dist. indicates the distance from the pole to the intersection point. Move the pole along the batter board and click [Measure]. Dist. now indicates a precise distance. The intersection point is found when Dist. equals zero.</p>	<p>[Measure]</p>	

NOTE :

After the first side of the Batter board has been measured and [S.O.] has been selected, it is assumed that the orientation of the batter board is perpendicular to the line connecting the two setout points. The distance D1 is calculated using this assumption. Next a second point on the batter board is measured. From now on the distance D1 will be calculated using the correct orientation of the

batterboard.D1 will now be more precise.

The error message 'Invalid value 'is shown if the batter board and the line connecting the two setout points are parallel.

The coordinates of the calculated intersection point are recorded in the coordinate file. The number of this intersection point is, compared to the highest existing number, incremented by one.

13.6 TAPE DIMENSIONS

Tape dim is a program which integrates surveying using a total station and a measuring tape. This program is especially useful when a quick survey of an object is required. It is assumed that all angles of this object are rectangular.

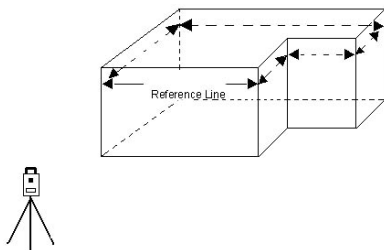



Measure an object by TAPE DIM. Two corners of the object are measured using the total station and a reference line is defined. Next the other sides of the object are measured using a measuring tape. When the last side is measured, the closing error will be shown.

Example:

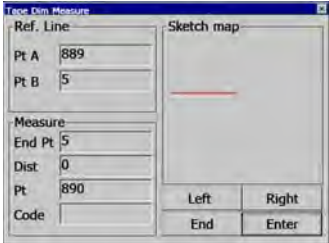
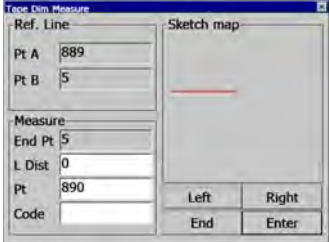
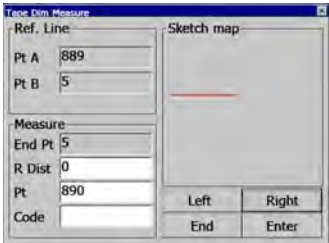
OPERATIONAL STEPS	KEY	DISPLAY
<p>① In [Program] menu, Click [Tape Dim].</p>	<p>[Tape Dim]</p>	
<p>② Enter PT A (Start PT) and PT B (End PT) on Re. Line and click [Enter].</p> <p>A</p> <p>If the point exists in project, then the Re. Line is defined.</p>	<p>[Enter]</p>	
<p>B</p> <p>If the point doesn't exist in project, the SS Measurement dialog box pops up. Measure and record this point.</p>		

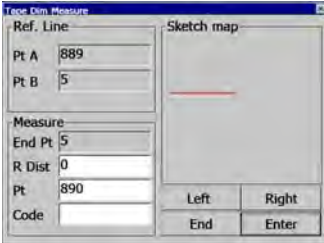
<p>③After defining Re. Line, click [Enter]</p> <p>[Enter]</p>	<p>[Enter]</p>	
<p>④The reference line is defined, now use a tape to measure the line which perpendicular to the reference line, and start from End PT of reference line.</p> <p>First select direction in which the straight line proceeds and enter Dist, PT and Code, and click [Enter]. The line is defined and displayed. If the line is at the left hand side, press [Left] key. If the line is at the right hand side of reference line, press [Right] key. ※1), ※2)</p>	<p>[Enter]</p> <p>[Left]</p> <p>[right]</p>	<p>A: Left</p>  <p>B: Right</p> 

<p>⑤ Repeat step ④ and Tape measure the object in light of its shape. The new line plus the reference line are graphically displayed.</p>		
<p>⑥ After measuring the last point, click [End], the screen displays the Misclose.</p>	<p>[End]</p>	
<p>⑦ Click [Yes], The display returns to standard survey main menu.</p>		
<p>※1) stipulation of Left, Right: Along with extending direction of straight line, turn left is Left. ※2) Inputting range of Dist: 0.001~1000</p>		

There are two ways to return to the main menu :

- 1) Press [ESC] key in case you have measured an open polygon. All points defined are automatically stored.
- 2) Click [End] to quit in case you have measured a closed polygon. The closing error (the distance between the last point and the first reference point) will be displayed. Click [OK] key to store all points defined and to return to main menu.

NOTE : The reference line and the lines defined by offsets are graphically shown only in case at least one offset has been entered.

14. SYSTEM SETTINGS

1, UNIT SETTING OPTIONS

Menu	Selecting Item	Contents
1. Ang. Unit	deg/gon/mil	Select degree (360°) , gon(400 G) or mil (6400 M) for the measuring angle unit to be shown on the display
2. Dist. Unit	Meter/Int. Feet/U.S Feet	Select the distance measuring unit Meter, Int. Feet or U.S Feet.
3. Temp. Unit	°C/ °F	Select the temperature unit for the atmospheric correction
4. Pres. Unit	mmHg/ hpa/ inHg	Select the air pressure unit for the atmospheric correction.

2, MEASURING SETTINGS

Menu	Selecting Item	Contents
1. Min. Ang. Min. Dist	1" /5" /0.1" 1mm/0.1mm	Select the minimum angle reading 1" /5" /0.1" . Select the minimum distance reading 1mm/0.1mm.
2. V-0	Zenith/Level	Select the vertical angle reading for Zenith 0 or Horizontal 0.
3. Tilt	OFF/1axis/2axis	Select the tilt sensor option for OFF, (1axis) vertical only or (2axis) vertical and horizontal

4.W-Corr.	0/0.14/0.20	Select the coefficient correction for refraction and earth curvature. Selections for the refraction coefficient are : OFF(No Correction) , K =0.14 or K =0.20
-----------	-------------	--

Correction for atmosphere refraction and the earth curvature

The instrument will automatically correct the effect of atmosphere refraction and the earth curvature when calculating the horizontal distance and the height differences.

The correction for atmosphere refraction and the earth curvature are done by the formulas as follows:

Corrected Horizontal Distance: $D = S * [\cos\alpha + \sin\alpha * S * \cos\alpha (K-2) / 2Re]$

Corrected Height Differentia: $H = S * [\sin\alpha + \cos\alpha * S * \cos\alpha (1-K) / 2Re]$



If the correction of atmosphere refraction and the earth curvature is neglected, the calculation formula of horizontal distance and the height differentia are:

$$D = S \cdot \cos\alpha \quad H = S \cdot \sin\alpha$$

In formula: **K=0.14** **Atmosphere Refraction Modulus**

Re=6370 km **The Earth Curvature Radius**



α (or β) **The Vertical Angle Calculated From Horizontal Plane (Vertical Angle)**

S..... **Oblique Distance**

NOTE: The atmosphere refraction modulus of this instrument has been set as: K=0.14. The value of K can be 0.14, 0.2, or

shut: (0 VALUE)

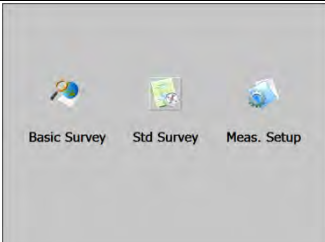
Example:

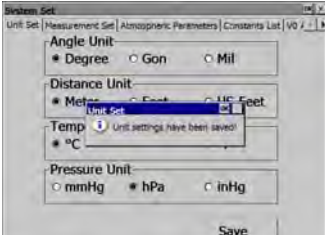
OPERATIONAL STEPS	KEY	DISPLAY
<p>① In the main menu click "Meas. Setup".</p>	<p>[Meas. Setup]</p>	
<p>② Click options of setting parameter.</p>		
<p>③ After setting, click [Save].</p>	<p>[Save]</p>	

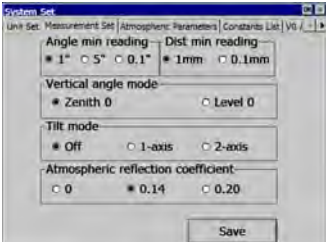
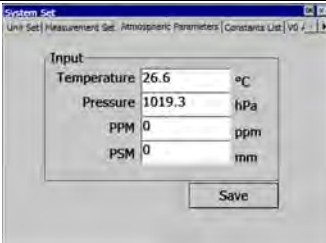
<p>④ Click[OK], the settings are saved.</p>	<p>[OK]</p>	
<p>⑤ Repeat steps ②~④ to make the measurement setting. After setting, click "X".</p>		
<p>⑥ Atmospheric Parameters. It read temperature and pressure by sensor automatically. You can also edit by yourself.</p>		

15. CHECK AND ADJUSTMENT

This instrument has undergone a strict process of checking and adjustment, which ensures that it meets quality requirement. However, after long periods of transport or under a changing environment, there may be some influences on the internal structure. Therefore, before the instrument is used for the first time, or before precise surveys, user should launch check and adjustment introduced in this chapter to ensure the precision of the job.

15.1 PLATE VIAL

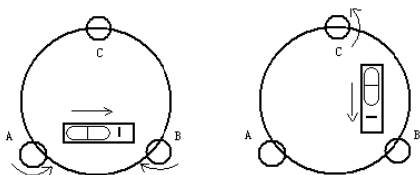

Check

Please refer to Chapter 3.2 “Leveling by Using Plate Vial”

Adjust

1. Adjust leveling screws, make plate bubble centered;
2. Rotate the instrument 180° ; watch the offset of plate level;
3. Tweak adjustment screws (on the right of the plate vial) with the correction pin to make plate bubble to move half of the offset back;
4. Rotate the instrument 180° , check adjustment result;
5. Repeat the above steps until the plate level is centered in all directions.

15.2 CIRCULAR VIAL

Check:

No adjustment is required if the bubble of circular vial is in the center after checking and adjustment of the plate vial.

Adjust

1. Adjust circular bubble after plate bubble is centered.
2. Loosen the screw (one or two) opposite with bubble deflective direction;
3. Tighten the screw on the direction accordant deflective until circular bubble is centered;
4. Adjust three adjustment screws for several times until circular bubble is centered;
5. The force power fixing three adjustment screws must be consistent when circular level is centered at last.

15.3 INCLINATION OF RETICLE

Check:

1. Sight object A through the telescope and lock the horizontal and vertical clamp screws.
2. Move object A to the edge of the field of view with the vertical tangent screw (point A')
3. Adjustment is not necessary if object A moves along the vertical line of the reticle and point A' still in the vertical line. As illustrated, A' offsets from the center to the cross hair tilts, then need to adjust the reticle.

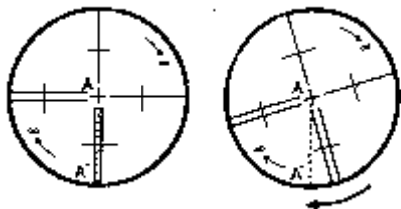

Adjust

1. If the object A does not move along with the vertical line, firstly remove the eyepiece cover to expose the three or four reticle adjusting screws.
2. Loosen all the reticle adjusting screws uniformly with an adjusting pin. Rotate the reticle around the sight line and align the vertical line of the reticle with point A'.
3. Tighten the reticle adjusting screws uniformly. Repeat the inspection and adjustment to see if the adjustment is correct.
4. Replace the eyepiece cover.

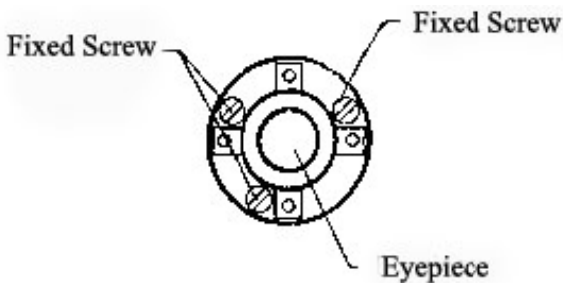

15.4 PERPENDICULARITY BETWEEN LINE OF SIGHT AND HORIZONTAL AXIS (2C)

Check

1. Set object A at about 100 meters away the same height as the instrument, and make the vertical angle with $\pm 3^\circ$. Then level and center the instrument and turn on the power
2. Sight object A in Face1 and read the horizontal angle value. (e.g.: Horizontal angle L = $10^\circ 13' 10''$).
3. Loosen the vertical and horizontal clamp screws and rotate the telescope. Sight object A in Reverse face and read the horizontal angle value. (e.g.: Horizontal angle R = $190^\circ 13' 40''$).
4. $2C = L - R \pm 180^\circ = -30'' \geq \pm 20''$, adjustment is necessary.

Adjust

A. Electronic Adjustment Operation Steps:

OPERATIONAL STEPS	KEY	DISPLAY
<p>① After leveling the instrument, in the main menu click[System Setup].</p>		<p>The screenshot shows a 'System Set' dialog box with the following options:</p> <ul style="list-style-type: none"> Unit Set: Measurement Set Atmospheric Param... Angle Unit: <input checked="" type="radio"/> Degree <input type="radio"/> Gon <input type="radio"/> Mil Distance Unit: <input checked="" type="radio"/> Meter <input type="radio"/> Feet <input type="radio"/> US-Feet Temperature Unit: <input checked="" type="radio"/> °C <input type="radio"/> °F Pressure Unit: <input type="radio"/> mm-Hg <input checked="" type="radio"/> hPa <input type="radio"/> in-Hg Buttons: OK, X, Save

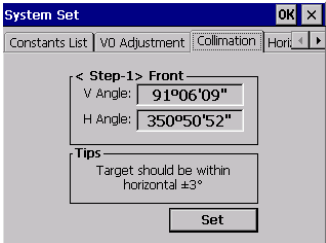
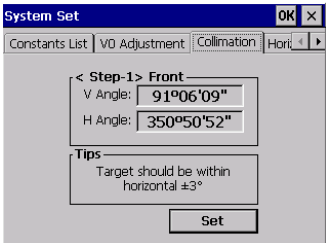
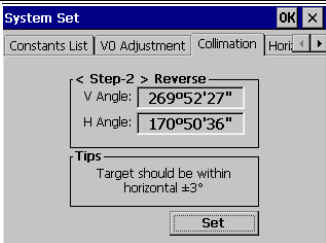
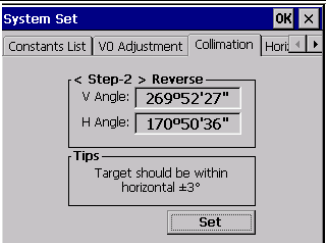
<p>② In the menu bar click  to show Collimation as right.</p>		
<p>③ In Face I precisely collimate the target, and press [Set].</p>	<p>Collimate the target [Set]</p>	
<p>④ Rotate the telescope and precisely sight the same target in Reverse face. Click[Set].</p>	<p>Sight prism in Reverse face [Set]</p>	
<p>⑤ After setting, the screen displays as right. Click[Set].</p>	<p>[Set]</p>	

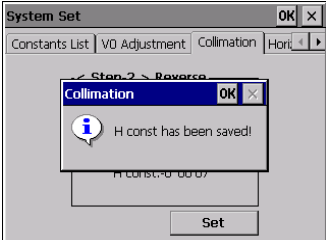
<p>⑥ Click[OK] to finish adjustment of collimation.</p>	<p>[OK]</p>	
---	-------------	---

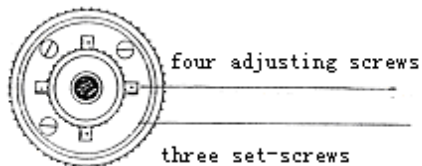

B. Optics Adjustment(professional maintenance man only)

1. Use the tangent screw to adjust the horizontal angle to the right reading which has been eliminated C, $R+C=190^{\circ}13'40''-15''=190^{\circ}13'25''$
2. Take off the cover of the reticle between the eyepiece and focusing screw. Adjust the left and right adjusting screws by loosening one and tightening the other. Move the reticle to sight object A exactly.
3. Repeat inspection and adjustment until $|2C| < 20''$.
4. Replace the cover of the reticle.

Note: After adjustment, need to check the photoelectricitycoaxiality.

15.5 VERTICAL INDEX DIFFERENCE COMPENSATION

Check

1. Mount and level the instrument and make the telescope parallel with the line connecting the center of the instrument to any one of the screws. Lock the horizontal clamp screw.
2. After turning on the power, zero the vertical index. Lock the vertical clamp screw and the instrument should display the vertical angle value.
3. Rotate the vertical clamp screw slowly in either direction about 10mm in circumference, and the error message “b” will appear. The vertical axis inclination has exceeded $3'$ at this time and exceeds the designated compensation range.
4. Rotate the above screw to its original position, and the instrument display screen will show the vertical angle again, meaning that the vertical index difference compensation function is working.

Adjust

If the compensation function is not working, send the instrument back to the factory for repair.

15.6 ADJUSTMENT OF VERTICAL INDEX DIFFERENCE (I ANGLE) AND SETTING VERTICAL INDEX 0

Inspect the item after finishing the inspection and adjustment of items in 15.3 and 15.5.

Check

1. Power on after leveling the instrument. Collimate object A in Face I and read the Vertical angle value L.
2. Rotate the telescope. Sight object A in Face II and read the Vertical angle

value R.

3. If the vertical angle is 0° in zenith, $I=(L+R-360^\circ)/2$

If the vertical angle is 0° in zenith, $I=(L+R-180^\circ)/2$ or $(L+R-540^\circ)/2$

4. If $|i| \geq 10''$ should set the Vertical Angle 0 Datum again.

Adjust:

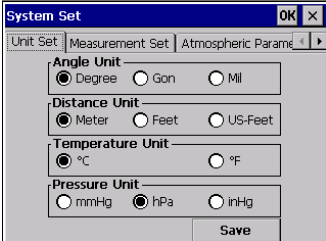
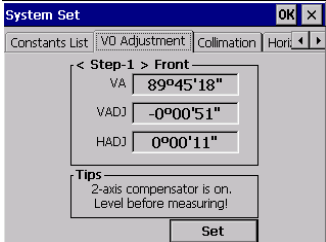
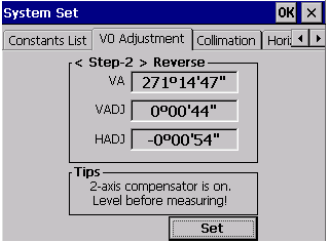
OPERATIONAL STEPS	KEY	DISPLAY
<p>① After leveling the instrument, click System Setup in the main menu.</p>	<p>[System Setup]</p>	 <p>The screenshot shows the 'System Set' window with the following options:</p> <ul style="list-style-type: none"> Angle Unit: <input checked="" type="radio"/> Degree, <input type="radio"/> Gon, <input type="radio"/> Mil Distance Unit: <input checked="" type="radio"/> Meter, <input type="radio"/> Feet, <input type="radio"/> US-Feet Temperature Unit: <input checked="" type="radio"/> °C, <input type="radio"/> °F Pressure Unit: <input type="radio"/> mmHg, <input checked="" type="radio"/> hPa, <input type="radio"/> in-Hg <p>A 'Save' button is at the bottom right.</p>
<p>② In the menu bar, click VO Adjustment. Sight the target precisely in the front face, click[Set].</p>	<p>Sight the target [Set]</p>	 <p>The screenshot shows the 'System Set' window with the 'VO Adjustment' tab selected. It displays the following values:</p> <ul style="list-style-type: none"> VA: 89°45'18" VADJ: -0°00'51" HADJ: 0°00'11" <p>A 'Tips' box indicates: '2-axis compensator is on. Level before measuring!'. A 'Set' button is at the bottom.</p>
<p>③ Rotate the telescope and precisely sight the same target in Reverse face. Click[Set].</p>	<p>Sight the prism [Set]</p>	 <p>The screenshot shows the 'System Set' window with the 'VO Adjustment' tab selected. It displays the following values:</p> <ul style="list-style-type: none"> VA: 271°14'47" VADJ: 0°00'44" HADJ: -0°00'54" <p>A 'Tips' box indicates: '2-axis compensator is on. Level before measuring!'. A 'Set' button is at the bottom.</p>

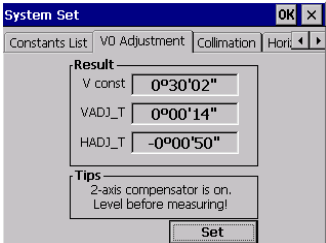
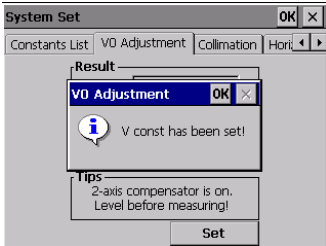
<p>④ After setting, the screen displays as right. Click[Set].</p>	<p>[Set]</p>	
<p>⑤ Click[OK] to finish adjustment of index error.</p>	<p>[OK]</p>	

Note:

1. Repeat the checking steps to measure the Index Error (i angle). If the Index Error cannot meet the requirement; user should check whether the three steps of the adjustment and the collimation are right. Then set again according to the requirement.
2. If Index Error still not meets the requirement after the repeated operation, the instrument should be returned to factory for inspection and repair.
3. The vertical angle displayed in zero point setting hasn't been compensated or modified, only for reference during setting.

15.7 HORIZONTAL AXIS ERROR COMPENSATION ADJUSTMENT

As the horizontal axis error only affects the angle of sight, it can be only confirmed through observing the target the height of which is obviously lower or higher than the instrument.

To avoid the influence of sight axis, user must have an associated adjustment before adjusting sight axis.

It is unnecessary to collimate the prism or the target plane to ascertain the transverse axis error. Therefore user is enabled to launch this adjustment at any time. Select a recognizable point which is rather far away from the instrument, and much higher or lower than the instrument. Make sure it can be precisely collimated twice.

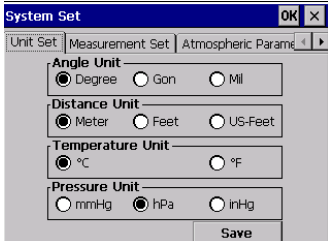
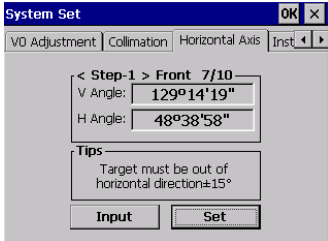
OPERATIONAL STEPS	KEY	DISPLAY
<p>① After leveling the instrument, click System Setup in the main menu.</p>	<p>[System Setup]</p>	
<p>② In the menu bar click Horizontal Axis. The screen displays as right. Sight the target precisely in front face, Click[Set]10 times.</p>	<p>Sight the prism [Set]</p>	

SOUTH

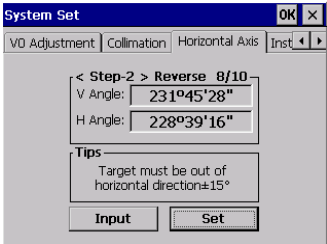
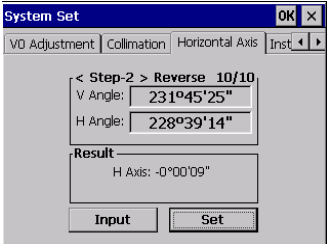
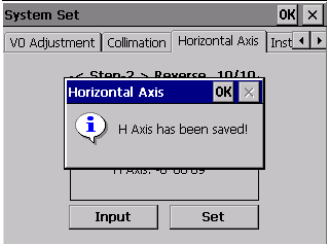
<p>③ Rotate the telescope and precisely sight the same target in reverse face. Click[Set]10 times.</p>	<p>sight the same target [Set]</p>	
<p>④ After setting, click[Set].</p>	<p>[Set]</p>	
<p>⑤ Click[OK] to finish adjustment of horizontal axis.</p>	<p>[OK]</p>	

15.8 OPTICAL PLUMMET

Check

1. Set the instrument on the tripod and place a piece of white paper with two crisscross lines on it right below the instrument.
2. Adjust the focus of the optical plummet and move the paper so that the intersection point of the lines on the paper comes to the center of the field of

view.

3. Adjust the leveling screws so that the center mark of the optical plummet coincides with the intersection point of the cross on the paper.
4. Rotate the instrument around the vertical axis, and observe whether the center mark position coincides with the intersection point of the cross at every 90° .
5. If the center mark always coincides with intersection point, no adjustment is necessary.

Otherwise, the following adjustment is required.

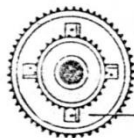
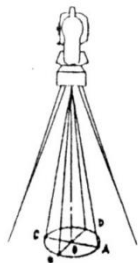

Adjusting Screws for plummet

(4 pcs)

Adjust

1. Take off the protective cover between the optical plummet eyepiece and focusing knob.
2. Fix the paper. Rotate the instrument and mark the point of the center of optical plummet which falls on the paper at every 90° . As illustrated: Point A, B, C, and D.
3. Draw lines that attach AC and BD and mark the intersection point of the two lines as O.
4. Adjust the four adjusting screws of the optical plummet with an adjusting pin until the center mark coincides with Point O.
5. Repeat the inspection and adjusting steps to make the instrument meets the requirements.

6. Replace the protective cover.

15.9 INSTRUMENT CONSTANT (K)

Instrument constant has been checked up and adjusted in the factory, $K=0$. It seldom changes and it is suggested to check one or two times every year. The inspection should be made on the base line, also can be made according to the following method.

·Check

1. Mount and level the instrument on Point A at a plain field. Use the vertical hair to mark Point B and Point C with the distance of 50m on the same line, and set the reflector accurately.
2. After setting temperature and air pressure, measure the horizontal distance of AB and AC accurately.
3. Set the instrument on Point B and center it accurately, measure the Horizontal Distance of BC accurately.
4. Then the Instrument Constant can be obtained:

$$K = AC - (AB + BC)$$

K should be near to 0, If $|K| > 5\text{mm}$, the instrument should be strictly inspected in the standard baseline site, and adjusted according to the inspection value.

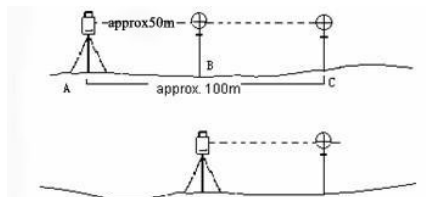

Adjust

If a strict inspection proves that the Instrument Constant K has changed and is not close to 0. If the operator wants to adjust, should set Stadia Constant according to the Constant K

1. Set the orientation via the Vertical Hair to maintain Point A, B, C on the same line precisely. There must be a fixed and clear centering mark on the ground of Point B
2. Whether the prism center of Point B coincides with the Instrument Center is a significant step to inspect the accuracy. So on Point B the tripod or compatible tribrach should be used. It will decrease the difference.

·Input Instrument Constant:

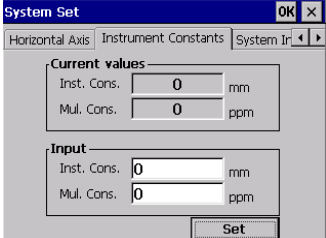
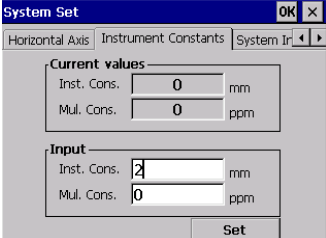
OPERATIONAL STEPS	KEY	DISPLAY
<p>① In [System Setup] menu, click [Instrument Constant]. The current Instrument Constant and Multiple Constant are displayed.</p>	<p>[Instrument Constant]</p>	
<p>② In Input New Values field enter new constant. You can enter Mul. Cons. Click [Set].</p>	<p>Input instrument constant [Set]</p>	

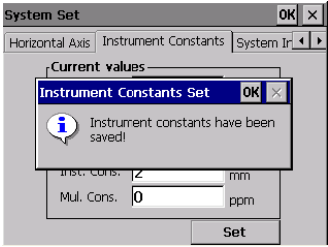
<p>③ Click[OK].</p>	<p>[OK]</p>	
<p>※1) Horizontal compensation adjust, vertical compensation and EDM adjusting: are set by the factory, please do not make any setting.</p>		

15.10 PARALLELISM BETWEEN LINE OF SIGHT AND EMITTING AXIS

Check:

1. Set the reflector 50m away from the instrument.
2. Collimate the center of the reflector prism with telescope reticle.
3. Switch on the instrument, and enter into Distance Measurement Mode. Press

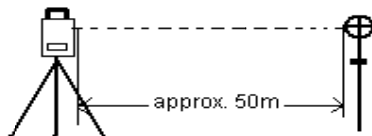

[DIST] (or [All]) to measure. Rotate the Horizontal Tangent Screw and Vertical Tangent Screw to launch electric collimation and make the light path of EDM unblocked. In the bright zone find the center of emitting photoelectric axis.

4. Check the center of reticle to coincide with the center of emitting photoelectric axis. If so, the instrument is proved eligible.

Adjustment:

If the center of reticle deviates from the center of emitting photoelectric axis, user should sent the instrument to professional repair department.

15.11 TRIBRACH LEVELING SCREW

If the leveling screw appears flexible, adjust the two adjusting screw in the leveling screw to tighten the screw appropriately.

15.12 RELATED PARTS FOR REFLECTOR

1 The Tribrach and Adapter for Reflector

The plate vial and optical plummet in the adapter and tribrach should be checked. Refer to Chapter 15.1 and 15.8 for more information.

2 Perpendicularity of the prism pole

As illustrated in Chapter 15.8, mark '+' on Point C, place the tine of the prism pole on the Point C and do not move during the inspection. Place the two feet tine of Bipod on the cross lines of Point E and F. Adjust the two legs "e" and "f" to make the bubble on the prism pole centered.

Set and level the instrument on Point A near the cross. Sight thetine of Point C with the center of reticle, and fix the Horizontal Clamp Screw. Rotate the telescope upward to make D near the horizontal hair. Flex the prism pole Leg "e" to make the D in the center of reticle. Then both Point C and D are on the central line of reticle.

Set the instrument on Point B to another cross lines. With the same way to flex the Leg "f" to make Point C and D on the

SOUTH

central line.

Through the adjustment of the instrument on Point A and B, prism pole has been perpendicular. If the bubble offsets from the center, adjust the three screws under circular vial to make the bubble centered.

Check and adjust again until the bubble is in the center of the vial from both directions of the prism pole.

16. Technical Specification

		N9	N70	N7
Distance Measurement				
Max.	Reflectorless	1000m	1000m	600m
Range	Reflector	3.5km		
Accuracy	Reflectorless	$\pm(3\text{mm}+2 \times 10^{-6} \cdot D)\text{mm}$		
	Reflector	$\pm(1 + 1 \times 10^{-6} \cdot D)\text{mm}$	$\pm(2\text{mm}+2 \times 10^{-6} \cdot D)\text{mm}$	
Reading				
Measuring Time		Fine Mode <0.3s; Tracking Mode<0.1s		
Atmospheric Correction		Auto Correction		
Prism Constant		Auto Correction		
Angle Measurement				
Measurement Method		Absolute Encoding		
Diameter of Absolute Encoding Disk		79mm		
Minimum Reading		0.1" or 1" option		
Accuracy		1"	2"	
Detection Method		Horizontal: Dual, Vertical: Dual		
Telescope				
Image		Erect		
Effective Aperture		48mm		
Magnification		30 X		
Field of View		1°30'		
Min. Focusing Distance		1.2m		
Automatic Compensator				

System	Dual-Axis Liquid-electric Sensor Compensation
Working Range	±4'
Accuracy	1"
Sensitivity of Vial	
Plate Vial	30" /2mm
Circular Vial	8' /2mm
Optical Plummet (Option)	
Image	Erect
Magnification	3 X
Focusing Range	0.5m - ∞
Field of View	5°
Laser Plummet (Default)	
Accuracy	1.5mm (in 1.5m InsHt)
Diameter	2.5mm (in 1.5m InsHt)
Wave Length	630nm—670nm
Laser Power	≤0.4mW
Display	
Type	640*480dpi, High-resolution LCD Touch Screen
Communication	
Data Support	RS-232、Min USB 、USB OTG、SD CARD
On-board Battery	
Power Supply	Rechargeable Lithium Battery
Voltage	7.2V dc
Operating Time	6 hours
Working Environment	

SOUTH

Temperature	-20°C ~ +50°C
Size	
Dimension	196mm×192mm×360mm
Weight	6.2kg

17. ACCESSORIES

Carrying Case	1pc
Main Body	1pc
Battery	2 pcs
Charger	1pc
Plummet	1pc
Correction Pin	2 pcs
Fur Brush	1pc
Screwdriver	1pc
Allen key	2 pcs
Cloth	1pc
Dryer	1pc
Operation Manual	1pc
Certificate	1pc
Stylus pen	2 pc
USB data cable	1 pc

1. EXPORT DATA FROM TOTAL STATION

After saving the data collected by total station by “Data Export” to appointed route, use U disk or synchronizing software (use Windows Mobile Device Center to synchronize total station and PC.) to copy to your computer, then you can view the data.

1.1 Raw Data Format

WinCE

(Identifier)	(Included information)
PROJECT	Project name, description of file saving path.
DATE	Date& time
NAME	name of the surveyor
INST	Serial number of instrument
UNITS	(unit)meter/feet/US-feet, degree, gon, mil
SCALE	Grid factor, scale, and height
ATMOS	Temp (°C), press (hPa)
STN	point ID, instrument height, identifier of station PT
XYZ	X(E), Y(N), Z(H)
BKB	Point number, Backsight azimuth,

Backsight angle

BS	Point number[, Target height]
FS	Point number, Target height, Point number coding[, String]
SS	Point number, Target height, Point numbercoding[, String]
CTL	control code[, point code 2[, String]](optional)

HV	HA(Horizontal angle), VA(Vertical angle)
SD	HA(Horizontal angle), VA(Vertical angle), SD(Slanting distance)
HD	HA(Horizontal angle), HD(horizontal distance), VD(Height differentia)
NOTE	note
RESOBS	Point number, Target height, observation times

1.2 Coordinate Data Format

Point number, E, N, H, code

111,1.059,1.059,1.298,,

112,1.000,1.000,2.596,,

113,1.059,1.059,1.297,,

114,1.059,1.059,1.297,,

115,1.059,1.059,1.297,,

Additionally, the coordinate format of point to line program is:

PT, E, N, Height, code, string, start reference PT, end reference PT

3,29.145,31.367,100.632,PT,1,2

4,128.365,56.367,115.732,PT,1,2

110,29.364,31.526,100.904,PT,101,103

111,49.892,3.958,112.834,PT,101,103

2. IMPORT DATA TO TOTAL STATION

Data can be imported includes coordinate data, fixed point data, code data, horizontal alignment data, vertical alignment data and cross section data. Create a new text file(.txt) on the computer, after editing and saving the data, use U disk or

synchronizing software (use Windows Mobile Device Center to synchronize total station and PC.) to copy to the total station, and use “Data Import to import to current project.

Data editing formats are displayed as follows.

2.1 Coordinate Data/Fixed Point Data Format

You should edit the coordinate data format on the computer as follows:

```
Point number, E, N, Z, code
1,1000.000,1000.000,1000.000,STN
2,990.000,1010.000,100.000,STN

101,994.890,1000.964,100.113,STN
102,993.936,1007.799,100.800,STN
103,998.515,1009.639,100.426,STN
104,1002.068,1002.568,100.342,STN
1001,1004.729,997.649,100.1153,PT
1002,1003.702,990.838,100.799,PT
1003,7911.990,990.358,100.403,PT
1004,997.311,998.236,100.354,PT
```

2.2 Cross Section Data Format

Cross section data format editing on the computer is as follows:

```
Chainage, Offset, Height[, code]
0.000,-4.501,18.527
0.000,-3.500,18.553
0.000,0.000,18.658,CL01
```

0.000,3.500,18.553

0.000,5.501,18.493

12.669,-4.501,18.029

12.669,-3.500,18.059

12.669,-0.000,18.164,CL01

12.669,3.500,18.059

12.669,5.501,17.999

2.3 Point P Coding Format

The code files enclosed in code library, should assure that every line has a code, which includes entity number and layer name, etc. Every entity is ended by carriage return.

The edited coding format is as follows:

Code[, Entity[, Layer]]

TREE,1,VEG

FENCE,2,BDY

CL,2,CL

EP,2,ROAD

GUTTER,2,ROAD

PATH,2,PATH

DRAIN,2,DRAIN

BM,1,CONTROL

MH,1,DRAIN

GUS,1,UTILITY

WATER,2,UTILITY

LP,1,UTILITY

LIGHTS,1,UTILITY

ROCK,2,NS

●When there is no definition in code library, the default value for entity is “1”, and for layer is “0”.

2.4 Horizontal Line

The horizontal line is transmitted from computer to instrument through line element, including initial definition. It should be included in initial definition the number of the start stake and coordinate of this point. The line elements include point, straight, arc, and transition curve.

Each recorded format is:

KEYWORD nnn,nnn[,nnn]

Here:

START POINT stake number, E, N

STRAIGHT azimuth, distance

ARC radius, arc length

SPIRAL radius, length

PT E, N[, A1, A2]

(A1, A2: LENGTH)

Example 1:

START 1000.000,01050.000,1100.000

STRAIGHT 25.0000,48.420

SPIRAL 20.000,20.000

ARC 20.000,23.141

SPIRAL 20.000,20.000

STRAIGHT 148.300,54.679

Example 2:

START 1000.000,1050.000,1100.000

PT 1750.000,1300.000,100.000,80.800

PT 1400.000,1750.000,200

PT 1800.000,2000.000

2.5 Vertical Curve

Input vertical curve data from computer through typical point and stake number, the vertical curve data should include the height, curve length, and the curve length of start point and terminal point is zero.

Data format is:

Stake number, height, length

1000.000,50.000,0.000

1300.000,70.000,300.000

1800.000,70.000,300.000

2300.000,90.000,0.000

【APPENDIX-B】 CALCULATE ROAD ALIGNMENT

The road alignment stake-out program can stake out the alignment elements including straight, arc and transition curve.

NOTE:

- Road alignment data can be uploaded from computer or can be entered manually. Transect data can only be uploaded from computer.
- Road alignment and transect data is managed by chainage.
- One job corresponds to one road alignment, you can use several jobs to create several alignments.

1. ROAD ALIGNMENT ELEMENTS

There are two ways to enter the alignment elements:

Download from PC.

Enter into WinCE(R) series in manual.

How to enter the alignment data is explained below:

Alignment Element	Parameter
Straight	Bearing, Distance
Transition Curve	Radius, Length of Transition Curve
Arc	Radius, Length of Arc
PT	N, E, radius, A1, A2

NOTE: When downloading from computer or selecting PT option, you do not have to calculate the Parameter.

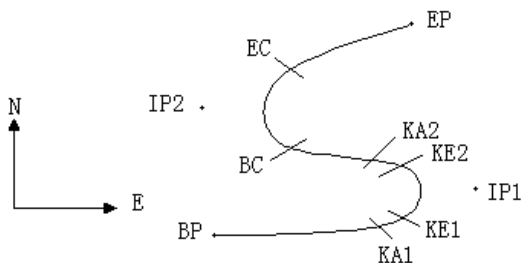

Pt	North (N)	East (E)	Radius (R)	Transition curve A1	Transition curve A2
BP	1100.000	1050.000			
IP1	1300.000	1750.000	100.000	80.000	80.000
IP2	1750.000	1400.000	200.000	0.000	0.000
EP	2000.000	1800.000			

Example:

To enter the following data select DEF AL of ROADS in PROG menu:

CH

N

E

Press [ENT] and then click (PT) on the screen, Enter the following data:

N

E

R

A1

A2

Enter the following data in the above way:

N	<input type="text" value="1750.000"/>
E	<input type="text" value="1400.000"/>
R	<input type="text" value="200.000"/>
A1	<input type="text" value="0.000"/>
A2	<input type="text" value="0.000"/>
N	<input type="text" value="2000.000"/>
E	<input type="text" value="1800.000"/>
R	<input type="text" value="0.000"/>
A1	<input type="text" value="0.000"/>
A2	<input type="text" value="0.000"/>

The format of the data above transmitted to computer is as follows:

START 0.000,1050.000,1100.000 CRLF

PT 1750.000,1300.000,100.000,80.000,80.000 CRLF

PT 1400.000,1750.000,200.000,0.000,0.000 CRLF

PT 1800.000,1800.000,2000.000 CRLF

2. CALCULATION ROAD ALIGNMENT ELEMENTS

(1) Calculation of the length of transition curve

$$L_{1.2} = \frac{A_{1.2}^2}{R} \quad L_{1.2} : \text{Length of clothoid}$$

$A_{1.2}$: Parameter of clothoid

R : Radius

$$L_1 = \frac{A_1^2}{R} = \frac{80^2}{100} = 64 \text{ m} \quad L_2 = \frac{A_2^2}{R} = \frac{80^2}{100} = 64 \text{ m}$$

(2) Calculation of Deflection Angle

$$\tau = \frac{L^2}{2A^2}$$

$$\tau_1 = \frac{64^2}{2 \cdot 80^2} = 0.32 \text{ rad} \quad = \text{deg} = 0.32 \frac{180}{\pi} = 18^\circ 20' 06''$$

$$\therefore \tau_1 = \tau_2$$

(3) Calculation of transition coordinates

$$N = A \cdot \sqrt{2\tau} \left(1 - \frac{\tau^2}{10} + \frac{\tau^4}{216} - \frac{\tau^6}{9360} \dots \right)$$

$$E = A \cdot \sqrt{2\tau} \left(\frac{\tau}{3} - \frac{\tau^3}{42} + \frac{\tau^5}{1320} - \frac{\tau^7}{7560} \dots \right)$$

$$N = 80 \cdot \sqrt{2 \cdot 0.32} \left(1 - \frac{(0.32)^2}{10} + \frac{(0.32)^4}{216} - \frac{(0.32)^6}{9360} \dots \right)$$

$$= 64 \left(1 - \frac{0.01024}{10} + \frac{0.01048576}{216} - \frac{0.00107341824}{9360} \right)$$

$$= 64(1 - 0.01024 + 0.00004855 - 0.00000011)$$

$$= 64 * 0.98981$$

$$= 63.348$$

Similarly, the value of E is:

$$\begin{aligned}
 E &= 80 \cdot \sqrt{2 \cdot 0.32} \left(\frac{0.32}{3} - \frac{(0.32)^3}{42} + \frac{(0.32)^5}{1320} - \frac{(0.32)^7}{7560} \dots \right) \\
 &= 64(0.106666667 - 0.00078019 + 0.0000025 - 0) \\
 &= 6.777
 \end{aligned}$$

This example is symmetry spiral transition $N_1=N_2$, $E_1=E_2$

(4) Calculation of shift value ΔR

$$\Delta R = E - R(1 - \cos \tau)$$

$$\Delta R = 6.777 - 100(1 - \cos 18^{\circ} 20' 06'')$$

$$= 1.700$$

Symmetry spiral transition $\Delta R_1 = \Delta R_2$

(5) Calculation of Spiral Transition coordinate

$$N_m = N - R \sin \tau = 63.348 - 100 \sin 18^{\circ} 20' 06'' = 31.891$$

Symmetry spiral transition $N_{m1} = N_{m2}$

(6) Calculation of Tangent Distance

$$D_1 = R \tan\left(\frac{LA}{2}\right) + \Delta R_2 \operatorname{cosec}(LA) - \Delta R_1 \cot(LA) + N_{m1}$$

$$LA = + 111^{\circ} 55' 47'' \quad , \quad \operatorname{cosec} = \frac{1}{\sin} \quad , \quad \cot = \frac{1}{\tan}$$

$$\begin{aligned}
 D_1 &= 100 * \tan(111^\circ 55' 47'' / 2) + 1.7(1 / \sin 111^\circ 55' 47'') \\
 &- 1.7(1 / \tan 111^\circ 55' 47'') + 31.891 \\
 &= 148.06015 + 1.8326 + 0.6844 + 31.891 \\
 &= 182.468 \\
 D_1 &= D_2
 \end{aligned}$$

(7) Calculation of the coordinate KA1

$$\begin{aligned}
 N_{KA1} &= N_{IP1} - D_1 \cdot \cos \alpha_1 \\
 E_{KA1} &= E_{IP1} - D_1 \cdot \sin \alpha_1
 \end{aligned}$$

Bearing from BP to IP1 = $\alpha_1 = 74^\circ 03' 16.6''$

$$N_{KA1} = 1300 - 182.468 * \cos 74^\circ 03' 16.6'' = 1249.872 \text{ m}$$

$$E_{KA1} = 1750 - 182.468 * \sin 74^\circ 03' 16.6'' = 1574.553 \text{ m}$$

(8) Calculation of Arc Length

$$\begin{aligned}
 L &= R(LA - \tau_1 + \tau_2) \\
 &= R(111^\circ 55' 47'' - 2 * 18^\circ 20' 06'') \\
 &= 100(75^\circ 15' 35'' \frac{\pi}{180^\circ}) \\
 &= 131.353 \text{ m}
 \end{aligned}$$

(9) Calculation of the coordinate KA2

$$N_{KA2} = N_{IP1} - D_2 \cdot \cos \alpha_2$$

$$E_{KA2} = E_{IP1} - D_2 \cdot \sin \alpha_2$$

$$\text{Bearing from IP1 to IP2} = \alpha_2 = 322^\circ 07' 30.1''$$

$$N_{KA2} = 1300 - (-182.468) \cdot \cos 322^\circ 07' 30.1'' = 1444.032 \text{ m}$$

$$E_{KA2} = 1750 - (-182.468) \cdot \sin 322^\circ 07' 30.1'' = 1637.976 \text{ m}$$

(10) Calculation of coordinates BC, EC which is ARC

(IP1, IP2, EP)

$$\text{Arc length } CL = R \cdot IA$$

$$IA = 95^\circ 52' 11''$$

$$CL = 200 \cdot 95^\circ 52' 11'' \cdot \frac{\pi}{180^\circ} = 334.648 \text{ m}$$

$$TL = R \cdot \tan\left(\frac{IA}{2}\right) = 200 \cdot \tan(95^\circ 52' 11'' / 2) = 221.615 \text{ m}$$

Each coordinates are computed :

$$N_{BC} = N_{IP2} - TL \cdot \cos \alpha_2$$

$$E_{BC} = E_{IP2} - TL \cdot \sin \alpha_2$$

$$N_{EC} = N_{IP2} - TL \cdot \cos \alpha_3$$

$$E_{EC} = E_{IP2} - TL \cdot \sin \alpha_3$$

here:

$$\alpha_2 \text{ (Bearing from IP1 to IP2)} = 322^\circ 07' 30.1''$$

$$\alpha_3 \text{ (Bearing from IP2 to EP)} = 57^\circ 59' 40.6''$$

$$N_{BC} = 1750 - 221.615 \cdot \cos 322^\circ 07' 30.1'' = 1575.068 \text{ m}$$

$$E_{BC} = 1400 - 221.615 * \sin 322^{\circ} 07' 30.1'' = 1536.058 \text{ m}$$

$$N_{EC} = 1750 - (-221.615) * \cos 57^{\circ} 59' 40.6'' = 1867.456 \text{ m}$$

$$E_{EC} = 1400 - (-221.615) * \sin 57^{\circ} 59' 40.6'' = 1587.929 \text{ m}$$

The calculated results display as below :

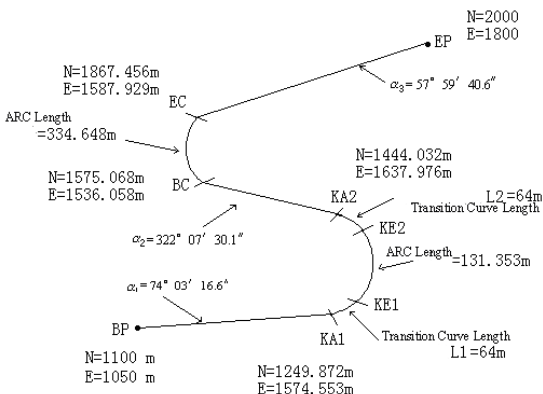

The coordinates and the distance are calculated as below :

Compute the length of straight line

Straight line

BP-KA1=

$$\sqrt{(1249.872 - 1100.000)^2 + (1574.553 - 1050)^2} = 545.543 \text{ m}$$

straight line

KA2·BC

$$= \sqrt{(1575.068 - 1444.032)^2 + (1536.058 - 1637.976)^2} = 166.005 \text{ m}$$

straight line

$$\text{EC} \cdot \text{EP} = \sqrt{(2000 - 1867.456)^2 + (1800 - 1587.929)^2} = 250.084 \text{ m}$$

Start point coordinate (BP)

N 1100.000 m

E 1050.000 m

straight line (between BP and KA1)

Bearing 74°03' 16.6"

Distance 545.543 m

Transition clothoid (between KA1 and KE1)

Radius -100 m ("-" sign is turn left curve toward the end point)

Length 64 m

ARC (between KE1 and KE2)

Radius -100 m ("-" sign is turn left curve toward the end point)

Length 131.354 m

Transition (Between KE2 and KA2)

Radius -100 m ("-" sign is turn left curve toward the end point)

Length 64 m

Straight line (between KA2 and BC)

Bearing 322°07' 30.1"

Distance 166.004 m

Arc (between BC and EC)

SOUTH

Radius 200 (without sign is turn right curve toward the end point)

Length 334.648 m

Straight line (between EC and EP)

Bearing 57°59' 40.6"

Distance 250.084 m

Dealer Info

SOUTH SURVEYING & MAPPING INSTRUMENT CO., LTD.

Email: mail@southsurvey.com export@southsurvey.com impexp@southsurvey.com euoffice@southsurvey.com
Http: [//www.southinstrument.com](http://www.southinstrument.com) www.southsurvey.com